

ORIGIN & ORIGIN EVO

Installation Guide - V3.0

Stereo Return (x4)

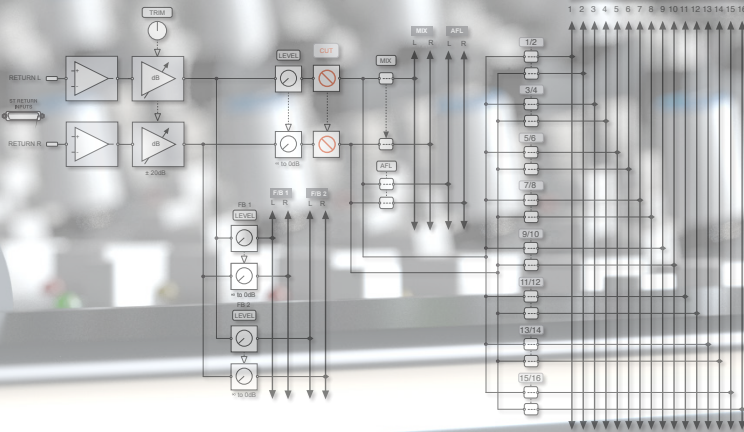

Stereo Groups (x4)

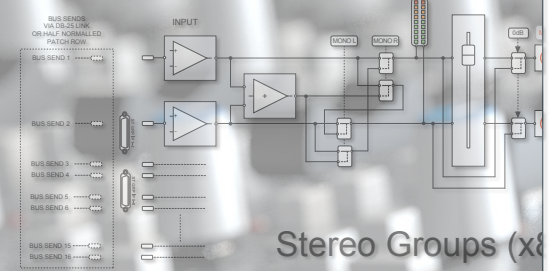

Communications (Foldback and Studio)

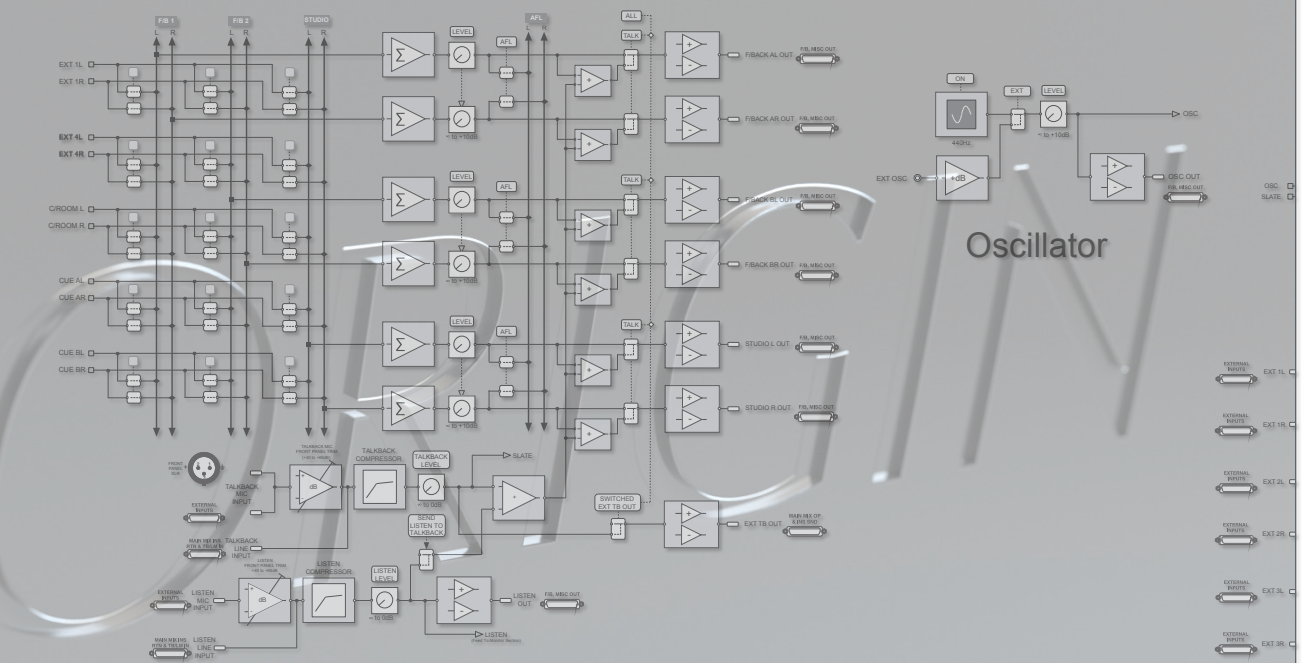

Oscillator

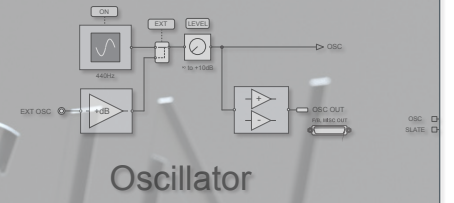

Solid State Logic

O X F O R D • E N G L A N D

Visit SSL at:
www.solidstatelogic.com

© Solid State Logic

All rights reserved under International and Pan-American Copyright Conventions

SSL® and Solid State Logic® are ® registered trademarks of Solid State Logic.

ORIGIN™, SuperAnalogue™, VHD™ and PureDrive™ are trademarks of Solid State Logic.

All other product names and trademarks are the property of their respective owners and are hereby acknowledged.

No part of this publication may be reproduced in any form or by any means, whether mechanical or electronic, without the written permission of Solid State Logic, Oxford, OX5 1RU, England.

As research and development is a continual process, Solid State Logic reserves the right to change the features and specifications described herein without notice or obligation.

Solid State Logic cannot be held responsible for any loss or damage arising directly or indirectly from any error or omission in this manual.

PLEASE READ ALL INSTRUCTIONS, PAY SPECIAL HEED TO SAFETY WARNINGS.

E&OE

January 2026

Revision History

Revision V1.0 - January 2020 - Initial Release
Revision V1.1 - February 2020 - First Minor Revision Release
Revision V1.2 - May 2020 - Correction of Leg Fixing Detail
Revision V1.3 - June 2020 - Revision of Installation Options
Revision V1.4 - January 2021 - Updated Crate Packing Detail
Revision V2.0 - September 2022 - Addition of Origin 16 Information
Revision V2.1 - May 2023 - Addition of Mains Supply Voltage & Current
Revision V2.2 - June 2023 - Revision of Special Tools to add details of Thumbscrews
Revision V3.0 - January 2026 - Addition of Origin Evo and Mk 2 Origin Frame

About ORIGIN

Launched in 2019, Origin is a fresh look at what large format consoles need to do to work in harmony with a modern DAW-driven production studio. The functional design looks back at the 'origin' of in-line consoles for signal flow inspiration, but its circuits are at the cutting edge of SSL's latest analogue developments.

The Origin Evo channel strip takes the same powerful twin path in-line channel Origin architecture and adds SSL's classic E-Series Dynamics processing. This additional processing brings additional requirements, so the Origin Evo channel also adds a Low Pass Filter to the Origin channel feature set, and of course this new processing also has the typical signal routing flexibility that users expect from an SSL in-line analogue console.

Origin's modern take on classic SSL circuits deliver huge dynamic range and bandwidth yet still have the characterful, pleasing qualities of space and depth that analogue audio breathes on digital audio.

A simple signal flow and layout make Origin easy to understand and use, the Origin Evo channel adds more processing and sophisticated signal routing capabilities, to give more creative options. Both Origin and Evo channels have powerful features such as channel direct outputs, a fully balanced electronic architecture and precision bargraph meters all of which make Origin a perfect partner for the highest quality converters and DAWs in the most professional production applications. ORIGIN EVO brings the console even closer to the original 4000 E with authentic E Series dynamics along with an added Low Pass Filter on every channel.

A unique and innovative modular centre section allows Origin to adapt to different applications and priorities, whether being used as a purely tracking console with additional boutique analogue additions to the 19" rack centre section, or a very digital/analogue hybrid approach with screens and controllers easily reached from the centre of the console.

Origin offers engineers and producers the tools required for everything from large-scale tracking to hybrid mix down session. Taking sustainability, ergonomics, modern gain-staging and communication requirements into consideration, Origin offers a reassuringly familiar Master Control feature-set with some ahead-of-the-curve functionality.



Table of Contents

Safety First!	1
Important Safety Information	1
General Safety	1
Power Safety	1
Definitions	2
Electrical Safety Warning	2
Safety Earth Connection	2
Mains Supply and Phases	2
Mains Isolation and Over-Current Protection	3
Physical Safety	3
Environmental	3
Tools	3
Regulatory Information	4
CE Certification	4
FCC Certification	4
Instructions for disposal of WEEE by users in the European Union	4
RoHS Notice	4
California Proposition 65	4
Help and Advice	5
Commissioning and Training	5
Warranty	5
Factory Warranty	5
Extended Warranty	5
Special Tools and Fasteners	5
User Guide	5
ORIGIN & EVO Power, Weight and Dimensions	6
General precautions	9
Unpacking	9
Safety Notices	9
IMPORTANT - ORIGIN & ORIGIN EVO Frame Structure and Manoeuvring The Console	9
Dismantling the shipping crate (32 Channel Console shown)	10
Mounting the console on the legs (if supplied)	11
Fitting/Removing the Sculpted End Trim	13
ORIGIN & ORIGIN EVO Master Section	15
About the ORIGIN Master Section and centre section rack layout	15
VERY IMPORTANT INFORMATION	15
Origin Mk2 Chassis	19
Making Connections - Origin & Origin Evo 16	22
Rear Connector Locations	22
Rear View - Power and Audio Connectors	23
Audio Connector Details	23
Microphone Inputs	23

Channel DB-25 Connectors	24
Channel DB-25 Pinouts.....	24
Channel DB-25 Pinouts cont'd.....	25
LF (Large Fader) Insert Returns.....	25
Channel DB-25 Pinouts cont'd.....	26
SF (Small Fader) Insert Returns.....	26
Master Section DB-25 Connectors.....	27
Master Section DB-25 Pinouts	27
Master Section DB-25 Pinouts Cont'd.....	28
Master Section DB-25 Pinouts Cont'd.....	29
Suggested Patchbay Layout - Origin & Origin Evo 16.....	30
Making Connections - Origin & Origin Evo 32.....	31
Rear Connector Locations	31
Rear View - Power and Audio Connectors	32
Audio Connector Details	32
Microphone Inputs.....	32
Channel DB-25 Connectors	33
Channel DB-25 Pinouts.....	33
Channel DB-25 Pinouts cont'd.....	34
LF (Large Fader) Insert Returns.....	34
Channel DB-25 Pinouts cont'd.....	35
SF (Small Fader) Insert Returns.....	35
Master Section DB-25 Connectors.....	36
Master Section DB-25 Pinouts	36
Master Section DB-25 Pinouts Cont'd.....	37
Master Section DB-25 Pinouts Cont'd.....	38
Suggested Patchbay Layout - Origin & Origin Evo 32.....	39
Appendix A - Performance Specification	40
Audio Performance.....	40
PureDrive™ Channel Input Microphone/Line Amplifier.....	40
Monitor Input Line Input Amplifier	40
Channel Equaliser	40
Overall Channel Signal Chain Specifications.....	41
Crosstalk.....	42
Overall Console Noise.....	42
Environmental Requirements	42
Appendix B - ORIGIN Block Diagram	43
Appendix B - ORIGIN EVO Block Diagram	44

Safety First!

Important Safety Information

This section contains definitions and warnings, and practical information to ensure a safe working environment. Please take time to read this section before undertaking any installation work.

Before use please also refer to the Safety Guide for ORIGIN, which is included in all new console shipments.

General Safety

- Please read and keep this document and adhere to all warnings and instructions.
- When installing this apparatus place it on a secure level surface.
- Do not block any ventilation openings and always allow free flow of air around the console for cooling.
- This electrical equipment should not be exposed to dust, water, or other liquids.
- Clean only with dry cloth or products compatible with electrical devices and never when the unit is powered.
- Do not operate near any heat sources, in direct sunlight or near naked flames.
- Do not place heavy objects on the unit.
- Unplug this apparatus during lightning storms or when unused for long periods of time.
- Only use attachments/accessories recommended by the manufacturer.
- Ensure that no strain is placed on any cables connected to this apparatus. Ensure that all cables are not placed where they can be stepped on, pulled or tripped over.
- Do NOT modify this unit, alterations may affect performance, safety and/or international compliance standards.
- SSL does not accept liability for damage caused by maintenance, repair or modification by unauthorised personnel.

Power Safety

- Origin is not supplied with a mains lead. When selecting a mains lead please comply with the following:
- Refer to the rating label on rear of the unit and always use a suitable mains cord.
- Please use-compliant 60320 C13 TYPE SOCKET. When connecting to supply outlets ensure that appropriate sized conductors and plugs are used to suit local electrical requirements.
- Maximum cord length should be 4.5m(15').
- The cord should bear the approval mark of the country in which it is to be used.
- The appliance coupler is used as the disconnect device, ensure that it is connected to an unobstructed wall outlet.
- Connect only to an AC power source that contains a protective earthing (PE) conductor.
- Only connect units to single phase supplies with the neutral conductor at earth potential.



CAUTION!

This equipment must be Earthed. Disconnect all power sources before removing any panels.
No user-serviceable parts inside - to be serviced only by qualified personnel.



WARNING!

Un-earthed metal parts may be present inside the enclosure. Check for hazardous voltages before touching.

Definitions

'Maintenance'

All maintenance must be carried out by fully trained personnel.

Note: It is advisable to observe suitable ESD precautions when maintaining electronic assemblies.

'Non-User Adjustments'

Adjustments or alterations to the equipment may affect the performance such that safety and/or international compliance standards may no longer be met. Any such adjustments must therefore only be carried out by fully trained personnel.

'Users'

This equipment is designed for use solely by engineers and competent operators skilled in the use of professional audio equipment.

'Environment'

This product is a class A product intended to form an integrated component part of a professional audio production environment wherein it will perform to specification providing that it is installed according to professional practice.

Electrical Safety Warning

When installing or servicing any item of SSL equipment with power applied, when cover panels are removed, HAZARDOUS CONDITIONS CAN EXIST.

These hazards include:

- High voltages
- High energy stored in capacitors
- High currents available from DC power busses
- Hot component surfaces

Any metal jewellery (watches, bracelets, neck-chains and rings) that could inadvertently come into contact with uninsulated parts should always be removed before reaching inside powered equipment.

Safety Earth Connection

Any mains powered item of SSL equipment must always have the earth wire connected to the mains supply ground AND PRECAUTIONS SHOULD BE MADE SO THAT THE GROUNDING IS NOT DEFEATED. This is the safety earth and grounds the exposed metal parts of the racks and enclosures and must not be removed for any reason.

WHEN CONNECTING TO MAINS SUPPLY OUTLETS ALWAYS REFER TO THE RATING LABEL ON THE REAR OF THE CONSOLE AND ENSURE THAT APPROPRIATE SIZED CONDUCTORS AND PLUGS ARE USED TO SUIT LOCAL ELECTRICAL REQUIREMENTS.

Mains Supply and Phases

To ensure safe operation of this equipment, connect only to an AC power source that contains a protective earthing (PE) conductor. This equipment is designed for connection to single phase supplies with the neutral conductor at earth potential – category TN or TT. This equipment is not designed for use with live and neutral connections reversed or where the neutral conductor is not at earth potential (IT supplies). This equipment should not be connected to a power system that switches open the return (neutral) lead when the return lead also functions as the protective earth (PE).

The ratings label, which details the console power requirements, is located adjacent to the mains inlet connectors on the power input panel beneath the rear of the console.

Mains Isolation and Over-Current Protection

An external disconnect device is required for this equipment which must be installed according to current wiring regulations. A detachable power cord is a suitable disconnect device.

An external over-current protection device is required to protect the wiring to this equipment which must be installed according to the current wiring regulations. The fusing or breaking-current is defined in the product specification. In certain countries this function is supplied by use of a fused plug.

Physical Safety

The console surface is too heavy for one person to move; ensure sufficient manpower is available when positioning the console and any associated IO or peripheral equipment.

If the console trim is removed for any reason then there may be sharp edges exposed on the frame metalwork.

Environmental

Temperature: Operating: +1 to 30 C . Storage: -20 to 50 C .

Tools

Origin is supplied with a pair of Thumbscrew Module Pullers (SSL Part #51DF7K9K) and a 2mm Allen Key to aid with maintenance of the channel strips. The Thumbscrews are supplied screwed into the console base at the front left hand side of the console as shown circled in red in this picture.



Other tools that may be needed for installation are an 8mm Metric (M8) spanner/socket or adjustable spanner to attach the legs. If there is a need to remove the end trim of the console, a #2 Pozidriv screwdriver will be needed for the front buffer/armrest to end trim screws.

Regulatory Information

CE Certification



ORIGIN is CE compliant. Note that cables supplied with SSL equipment may be fitted with ferrite rings at each end.

This is to comply with the current regulations and these ferrites should not be removed.

If any of the console metalwork is modified in any way – particularly the addition of holes for custom switches etc. – this may adversely affect the CE certification status of the product.

FCC Certification

This equipment has been tested and found to comply with the limits for a Class A digital device, pursuant to part 15 of the FCC Rules. These limits are designed to provide reasonable protection against harmful interference when the equipment is operated in a commercial environment.

This equipment generates, uses and can radiate radio frequency energy and, if not installed and used in accordance with the instruction manual, may cause harmful interference to radio communications. Operation of this equipment in a residential area is likely to cause harmful interference in which case the user will be required to correct the interference at his own expense.

Instructions for disposal of WEEE by users in the European Union



The symbol shown here, which is on the product or on its packaging, indicates that this product must not be disposed of with other waste. Instead, it is the user's responsibility to dispose of their waste equipment by handing it over to a designated collection point for recycling of waste electrical and electronic equipment. The separate collection and recycling of your waste equipment at the time of disposal will help to conserve natural resources and ensure that it is recycled in a manner that protects human health and the environment. For more information about where you can drop off your waste equipment

for recycling, please contact your local city office, your household waste disposal service or where you purchased the product.

RoHS Notice

Solid State Logic has conformed and this product has conformed to European Union's Directive 2011/65/EU on Restrictions of Hazardous Substances (RoHS) as well as the following sections of California law which refer to RoHS, namely sections 25214.10, 25214.10.2, and 58012, Health and Safety Code; Section 42475.2, Public Resources Code.



California Proposition 65

WARNING: Cancer and Reproductive Harm - www.P65Warnings.ca.gov

Help and Advice

Commissioning and Training

Commissioning

ORIGIN consoles do not include on-site commissioning by an SSL engineer as standard.

Commissioning can be requested at the time of purchase at additional cost and is usually expected to take one working day.

You should contact your local SSL office or agent at least four weeks prior to delivery to arrange a commissioning date.

Please note: The console must be installed in a clean environment. The presence of dust – particularly cement particles – increases the chance of long-term damage being caused to the moving faders and other controls. Such damage may cause the warranty to be rendered invalid.

Training

A range of operational and maintenance training options are available from SSL or one of our authorised representatives.

For further information please contact SSL's Support Department at: support@solidstatellogic.com.

Warranty

Factory Warranty

All new systems include a 13 month warranty which commences on the date of shipment. This warranty includes:

- Technical support – phone, fax and e-mail – via your local distributor or office during normal business hours
- Supply of exchange parts*
- Service engineer visits (note that travel and subsistence costs are not covered by the warranty)

* It is not anticipated that a visit from an SSL engineer will be necessary in the majority of cases where a replacement part is required. Console sub-assemblies are designed to be easily removable to facilitate replacement.

Extended Warranty

The standard warranty period may optionally be extended up to a maximum of 5 years on a 'Parts supply' basis.

To order extended warranty please contact your SSL representative or e-mail SSL's Service department at: support@solidstatellogic.com.

Special Tools and Fasteners

Each ORIGIN console is supplied with a pair of M4 Thumbscrew module removal tools (SSL Part No. 51DF7K9K) which fix into the threaded holes that are exposed when the upper and lower channel fixing screws are removed. (see note & picture on P3).

Other than this no special tools are required for maintenance. All fasteners are Metric sizes and threads. Most screws used to fix panels are M3 Hex headed countersunk or cap screws which need a 2 mm hex, or Allen key to remove, or they are Pozidriv #2 headed screws. The feet are fixed with 8 mm (M8) Hex nuts (supplied).

User Guide

The ORIGIN User Guide can be downloaded from the ORIGIN section of the SSL website at : <https://www.solidstatellogic.com>

ORIGIN & EVO Power, Weight and Dimensions

Approx. Dimensions are shown in mm [and feet-inches] in the diagrams below and on the following pages.
 Other specs are:

	ORIGIN & ORIGIN EVO 16	ORIGIN & ORIGIN EVO 32
Approximate Weight	198 lb / 90 kg including legs and trim 157 lb / 71 kg excluding legs	357 lb / 162 kg including legs and trim 315 lb / 143 kg excluding legs
Power Requirements	Mains Supply : Voltage : Autoranging 100V to 240V Current : 6.0 A to 3.0 A Power Consumption: Typically <500 Watts 600 Watts maximum when on Typically <40 Watts when in standby/ sleep.	Mains Supply : Voltage : Autoranging 100V to 240V Current : 12.0 A to 6.0 A Power Consumption: Typically <900 Watts 1200 Watts maximum when on Typically <40 Watts when in standby/ sleep.

Note : Origin and Origin EVO have very similar power consumption. This is due to power efficiency savings in the design of the Evo modules.

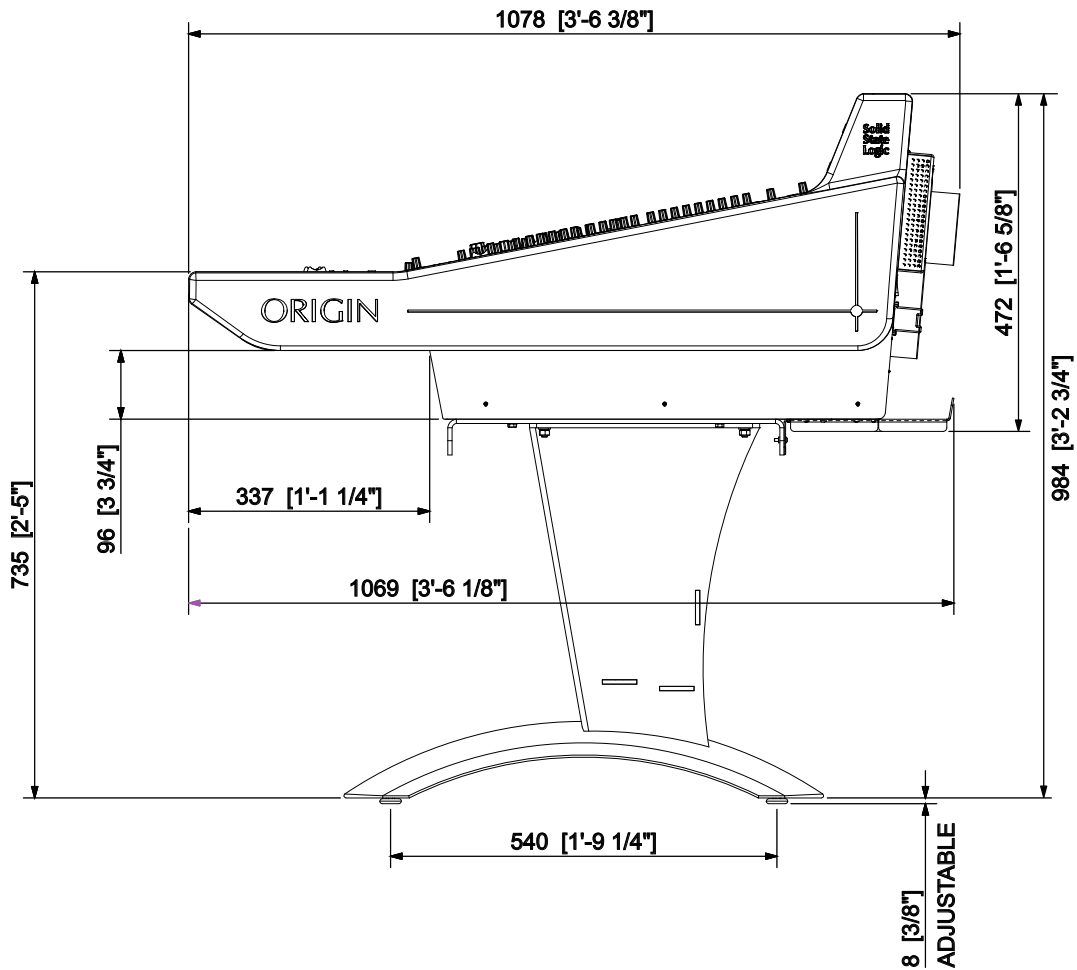

Origin & Origin Evo 16

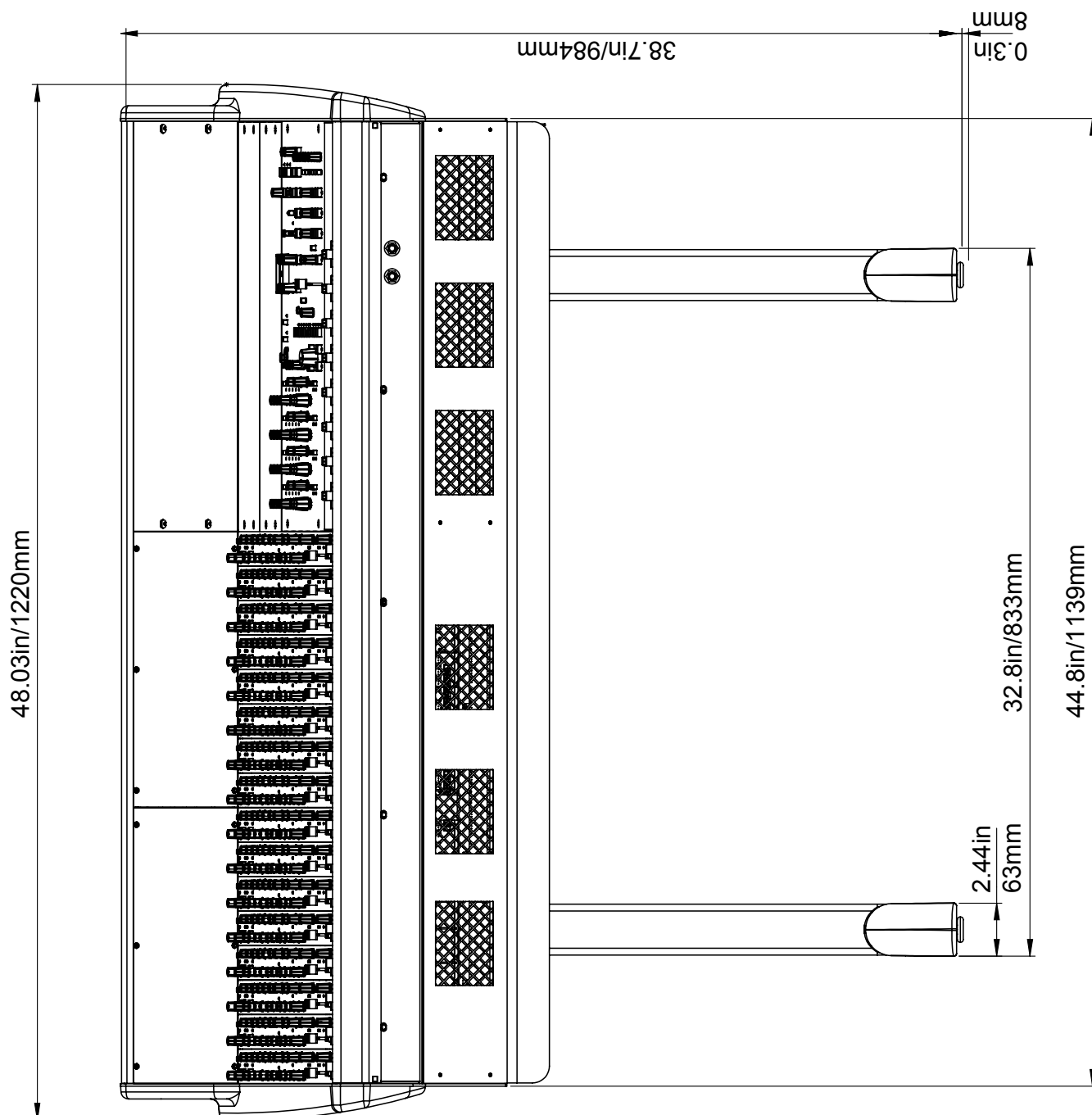

Origin & Origin Evo 32

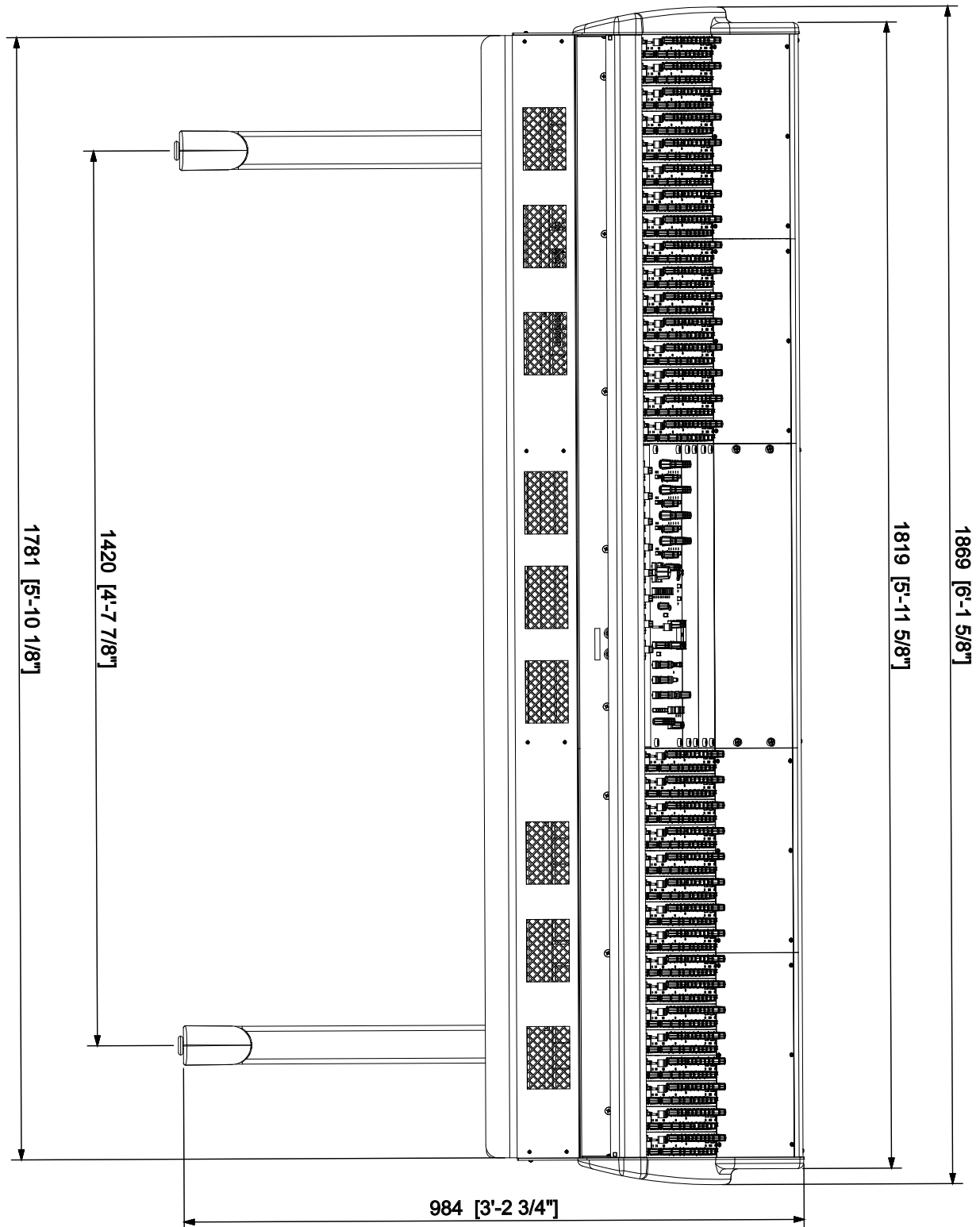

General precautions

- To prevent damage to the controls and cosmetics, avoid placing heavy objects on the control surface, obstructing the faders, scratching the surface with sharp objects, or rough handling and vibration.
- Protect the equipment from damage through liquid or dust contamination. Avoid dust or small objects getting into the fader slots. Power off and cover the console when it is not being used for a long period.
- Electronic technology can be affected by extreme cold. If the equipment has been stored in sub-zero temperatures allow time for it to reach normal operating temperature before use. Recommended operating temperature for ORIGIN & ORIGIN EVO is +1 degree (Non-condensing) to 40 degrees Celsius.
- Avoid using the equipment in extreme heat and direct sunlight. Make sure the console ventilation slots are not obstructed and that there is adequate air movement around the equipment.
- ORIGIN & ORIGIN EVO are designed to be permanently mounted in a fixed installation. If the console has to be moved, please consult SSL for packing and transportation advice.
- Avoid the use of chemicals, abrasives or solvents. Clean the control surface with a soft brush and dry lint-free cloth.
- It is recommended that servicing is carried out only by an authorised SSL support partner or agent. Contact details for your local distributor can be found on the SSL web site or by contacting support@solidstatellogic.com.
- SSL do not accept liability for damage caused by maintenance, repair or modification by unauthorised personnel.

WARNING: To reduce the risk of fire or electric shock do not expose this apparatus to rain or moisture.

ATTENTION: Afin de réduire les risques de choc électrique, ne pas exposer cet appareil à l'humidité ou à la pluie.

Unpacking

ORIGIN & ORIGIN EVO are supplied in a sealed wooden shipping crate similar to that shown:

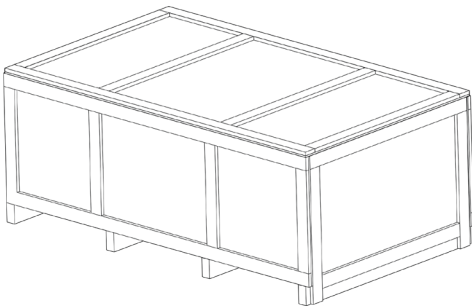

	ORIGIN & ORIGIN EVO 16	ORIGIN & ORIGIN EVO 32
Volumetric weight for shipping	210 kg, 460 lb	280 kg, 620 lb
Approximate Crate Dimensions		
Length :	1390mm (54.8 inches)	2040mm (80.3 inches)
Height :	680mm (26.8 inches)	680mm (26.8 inches)
Depth :	1210mm (47.6 inches)	1210mm (47.6 inches)

Safety Notices

IMPORTANT: Please read the safety notice information included in the Safety Guide supplied inside the box before using ORIGIN & ORIGIN EVO.

IMPORTANT - ORIGIN & ORIGIN EVO Frame Structure and Manoeuvring The Console.



The structure of ORIGIN & ORIGIN EVO is built on a strong steel U-beam which spans the width of the base of the console. Only this should be used to lift and manoeuvre the console when using a forklift or other mechanical lifting aid.

DO NOT USE THE OPTIONAL REMOVABLE END TRIM TO MOVE OR HANDLE THE CONSOLE.

Dismantling the shipping crate (32 Channel Console shown)

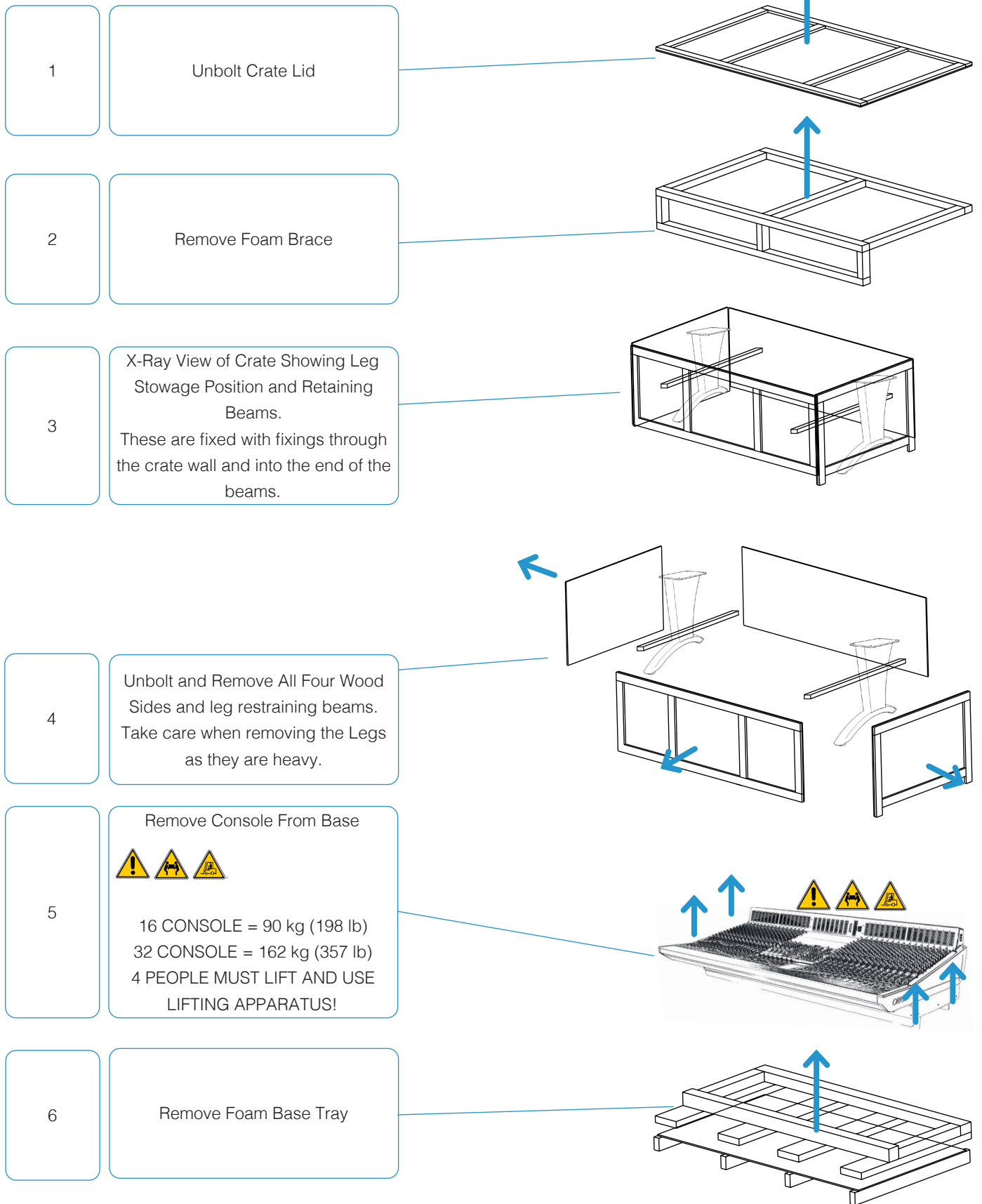

Mounting the console on the legs (if supplied)

Once the crate is dismantled, the next activity is to remove the console, legs and fixing nuts from the shipping crate and to mount the console on it's legs. It is suggested that the foam lattice used in the shipping crate is used to protect the floor and console when fitting the legs

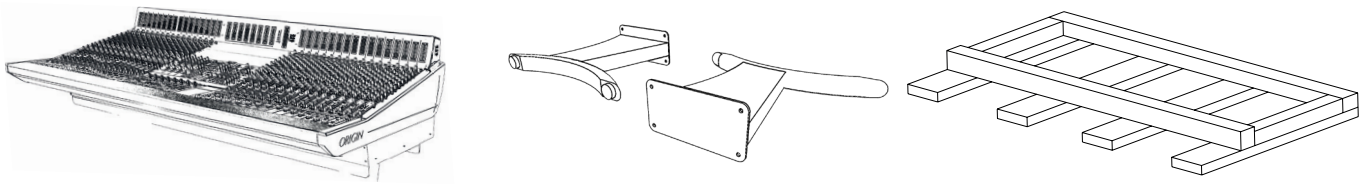

CAUTION: The 16 ch console weighs approx 90kg (198lb) and the 32 ch console weighs approx 150kg (330lb), multiple people and/or lifting supports must be used to remove the console from the shipping crate.

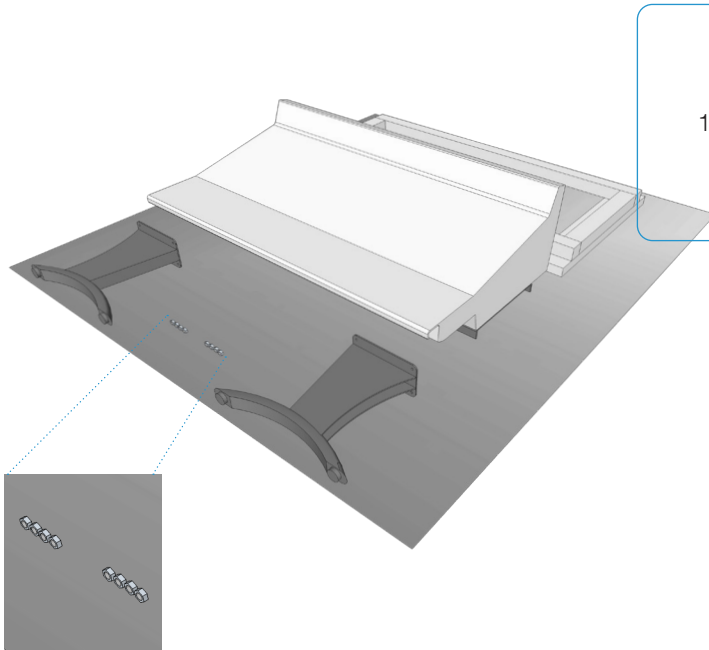

1

Ensure that the legs, leg fixings and console are conveniently located for assembly.
In the diagram on the left the foam base tray is in position behind the console to provide a cushioned base to protect the rear of the console and the floor when fitting the legs.



Lift** the console and gently place it onto its rear. The console will rest in a near vertical position on the rear panel heatsinks and the cable tray mounted on the rear edge.

**The console is heavy! Several strong people will be needed for this activity.

2

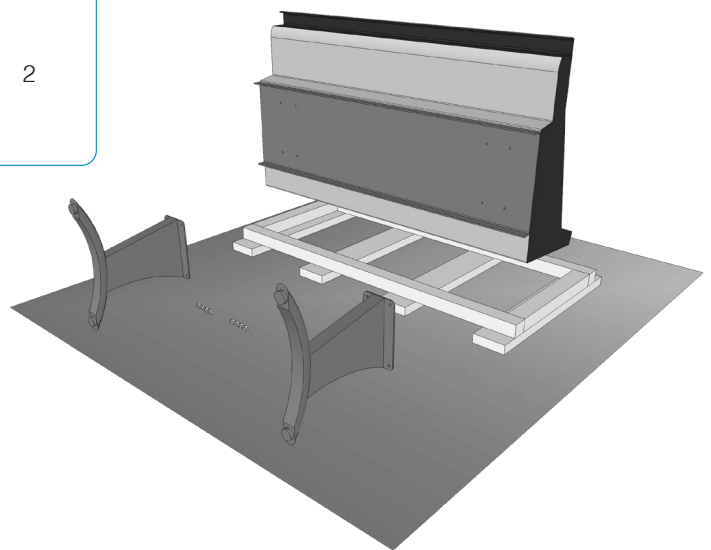

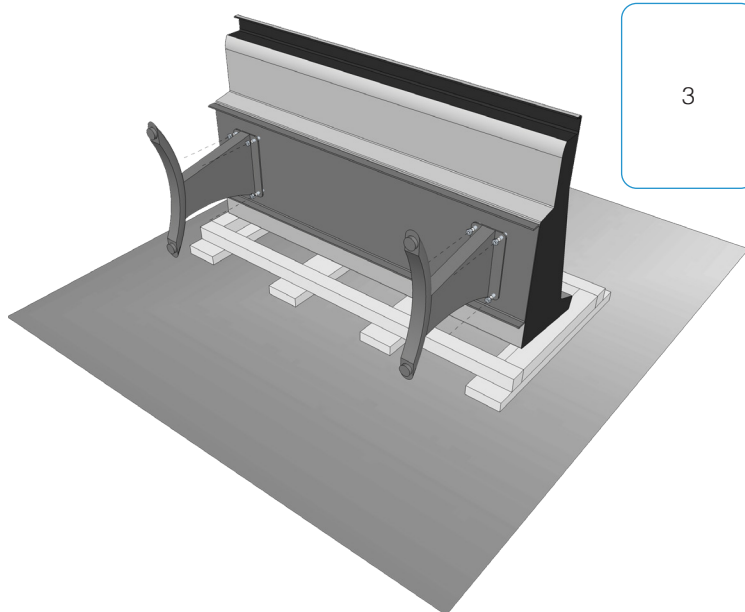

3

With the console carefully resting on its rear, use the eight M8 nuts supplied to attach the legs onto the studs protruding from the console base.

It is important for a person to support the console as the legs are attached as the additional weight of the legs will change the centre of gravity,

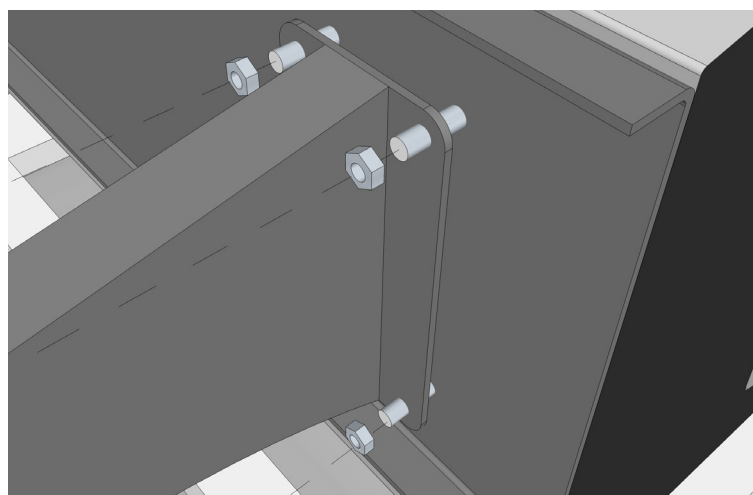

With the legs attached securely, the console can be lifted to its final position.

The rubber feet at the base of the legs have a small amount of screw adjustment allowing adjustment for uneven floors.

4

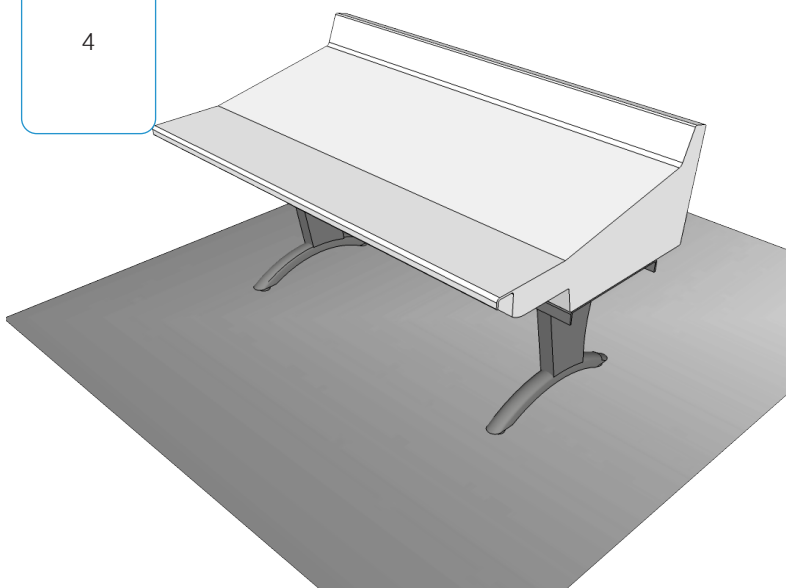

Fitting/Removing the Sculpted End Trim

If Sculpted End Trim has been ordered, this will normally be fitted prior to packing. It is possible to remove this end trim, for example to reduce the overall width of the console, or to provide a surface to mate to third party furniture.

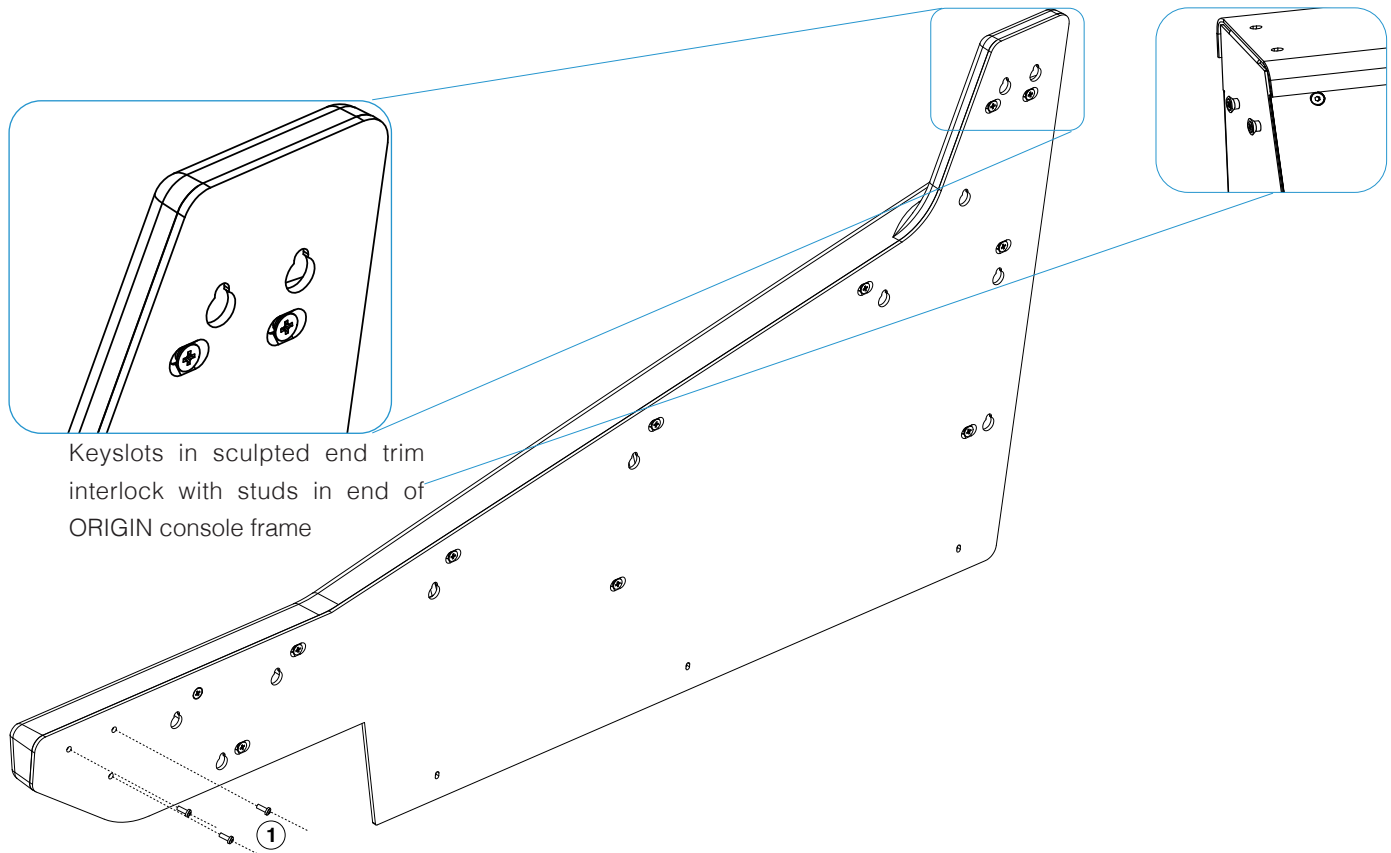

Removing the end trim starts with removing the three cross headed screws that secure the front buffer/armrest (1 in the diagram above) and the three 2mm hex headed retaining screws (2 in the diagram on the right) on the bottom edge of the trim. With these six screws removed the trim can be gently slid up vertically to align the keyhole slots with the locating lugs and then removing the trim horizontally.

Fitting the trim is the opposite process, i.e. position the trim keyhole locating apertures so they locate onto the end of the console over the locating studs, then gently slide the trim down vertically so that the bottom three locating screw holes align with the threaded holes in the end of the console, then screw the trim in place with the three trim retaining screws (2 in the diagram on the right) and the other three screws inside of the front buffer/armrest (1 in the diagram above).

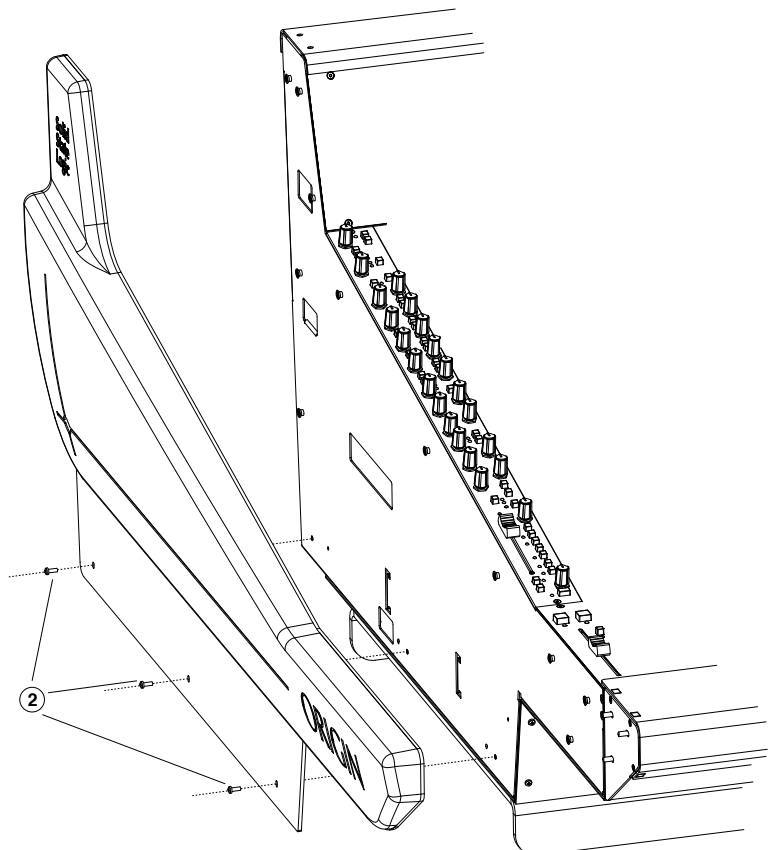

ORIGIN & ORIGIN EVO Master Section

About the ORIGIN Master Section and centre section rack layout.

The ORIGIN Master Section is designed to be the heart of a flexible, configurable central layout. The 6U 19" rack width is designed to be re-positionable for different application priorities. As standard, the master section is fitted in the bottom 6U of the 12U central rack layout and there are two 3U panels blank panels above. The Master Section is cabled such that it can be placed in any of the rack slots from the lowest 6U to the top 6U and therefore the blank panels may be re-arranged to support other third party devices such as keyboards, or controllers. Additionally custom 19" panels, such as switch panels, or trays for controllers may be fitted.

It is possible to fit shallow audio devices, such as 500 series rack modules, into the upper areas of the centre racking, care should be taken that any devices fitted do not introduce overheating issues, either because of their own power consumption, or because they restrict airflow, see the IMPORTANT INFORMATION below.

MASTER SECTION RACK CABLE ACCESS

Cable access for 19" rack units is available through an access hole at the rear of the base of the cavity (see diagram below).

VERY IMPORTANT INFORMATION

HEAT AND VENTILATION

As shown in the drawing below, ventilation through the internal cavity of the centre section is very important. Any device which is fitted into the racking which significantly restricts airflow through the central cavity could create overheating issues for the electronics in the Master Section. Deep units which could significantly obstruct airflow should have at least a 1U ventilation panel underneath their rack position to allow airflow through the Master Section.

ELECTRICAL NOISE AND INTERFERENCE

Any additional electronics mounted in the centre section racking could expose the Master Section to electrical noise/interference and compromise the audio performance of ORIGIN. Obviously, SSL cannot be responsible for any issues that may arise because of this and owners should remove any devices causing such issues to preserve the audio performance of the console.

MOVING THE MASTER SECTION

Though the Master Section is designed to be re-positioned, it is not designed for continuous changes of position, it is moveable to configure the console for different applications, not to be moved for each session.

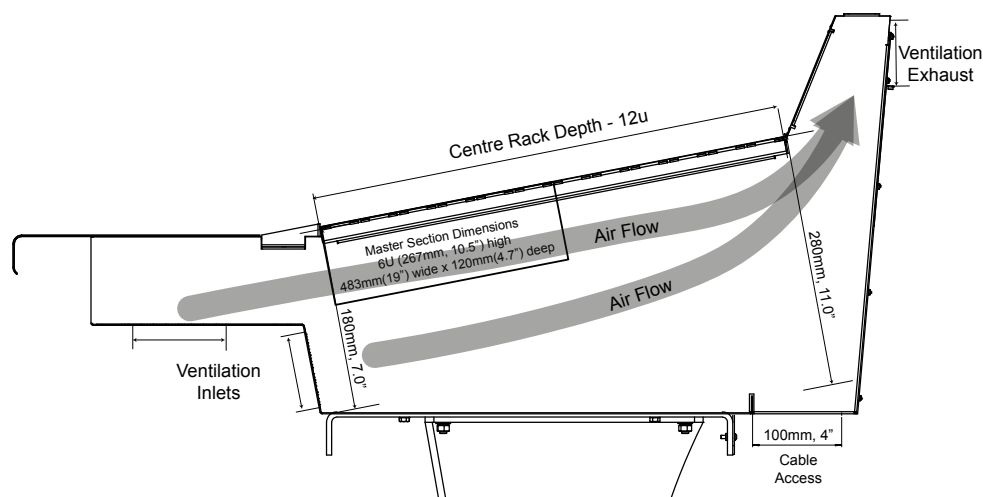



Standard Layout

The layout on the left is the default layout from the factory. As can be seen, all the panels above the Stereo Group faders are 19" format panels. The Master Section is a 6U panel and above that are two 3U panels. The Meter Panel in the overbridge is also a 3U panel.



500 Series Racks

In this layout, the two 3U panels have been replaced with a 500 series rack fitted with 8 mono SSL Dynamics modules and a stereo SSL Bus Compressor. A 1U grill panel has been fitted above the centre section to aid with ventilation and the remaining 2U filled with a 2U blank panel.

The lower right blank area next to the Stereo Group faders has an Apple Magic Trackpad placed on it to show for scale.

IMPORTANT:

Please read the **VERY IMPORTANT INFORMATION** on the previous page before fitting any electronic devices into the centre section racking.



Full Sized Keyboard

In this layout, the Master Section has been moved towards the rear of the console by 3U**. A blank 3U panel has been moved into the space above the Stereo Group Faders and this can be used for a computer keyboard. The lower right blank area next to the Stereo Group faders has an Apple Magic Trackpad.

**NOTE: Moving The 6U Master Section

The 6U ORIGIN Master Section has many of the console audio and control signals wired to it. Please exercise anti-static precautions before moving and take great care to ensure no cables are snagged or disconnected when moving.



DAW Controller Layout

In this layout, the Master Section has been moved to the top 6U of the console centre section. The two 3U blank panels have been moved into the space above the Stereo Group Faders and this space is used for a DAW controller.

**NOTE: Moving The 6U Master Section

The 6U ORIGIN Master Section has many of the console audio and control signals wired to it. Please exercise anti-static precautions before moving and take great care to ensure no cables are snagged or disconnected when moving.



Alternate Meter Layout

As the centre meters are also built as a 3U panel, they can also be moved into the upper 3U in the Centre Section. In the images shown, the blank 3U panel is moved into the overbridge to keep the centre meters visible if the overbridge space is likely to be obscured (for example by a flat screen monitor, see image below)



Centre Section Racking

The MAXIMUM** depth for each 1U of the centre section rack space is shown below. The 11th and 12th U of rack space are angled such that a deep unit could extend through the cable entry space in the rear of the console. With any rack units that restrict air flow through the centre section, ventilation rack panels must be used to keep airflow through the Master Section.

** MAXIMUM depth available includes cables, connectors and cable bend radiuses.

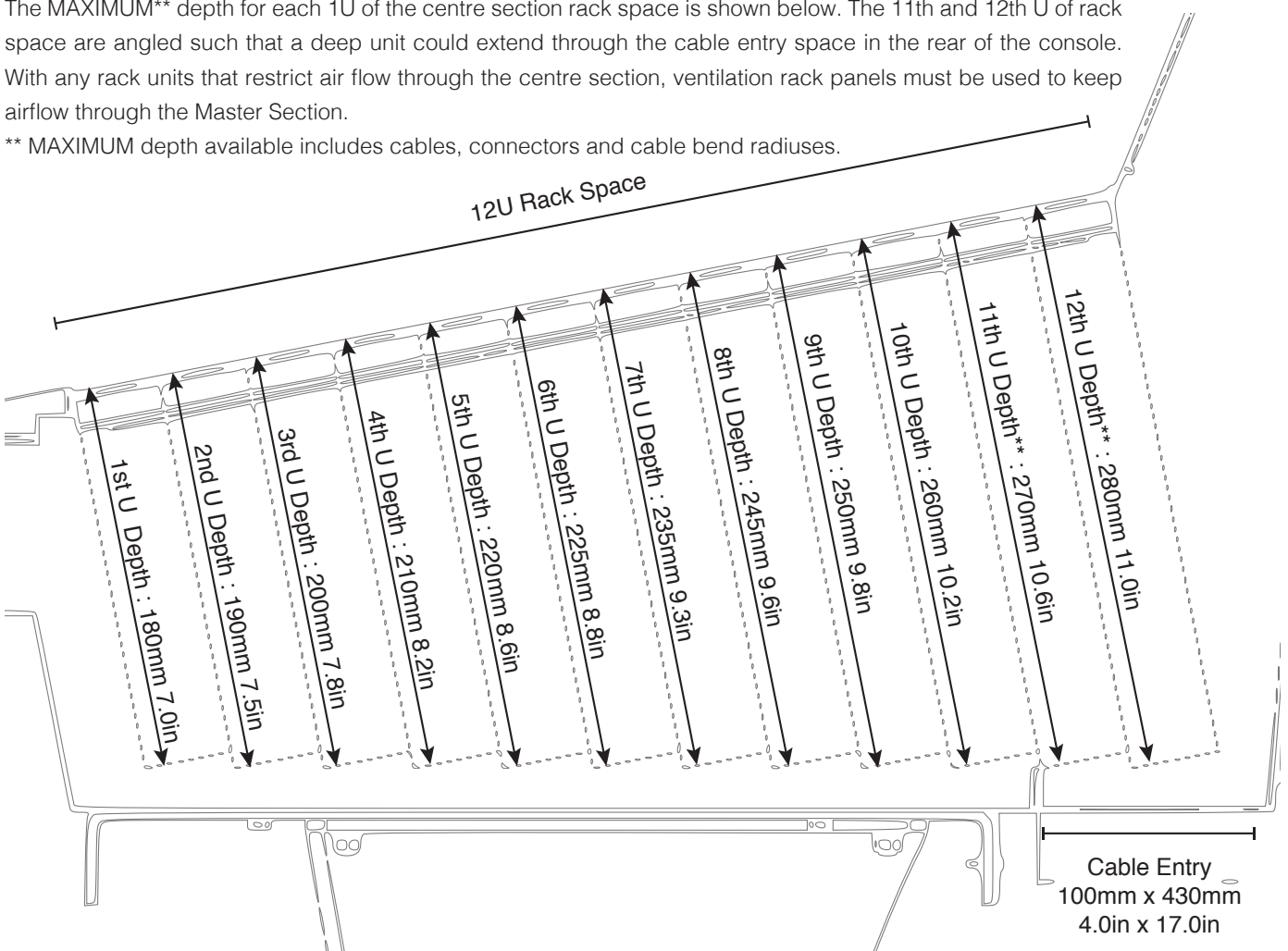

Origin Mk2 Chassis.

Alongside the introduction of the Origin Evo channel, there is also a Mk2 Origin chassis used for both Origin & Origin Evo consoles. This introduces some subtle changes to the standard Origin Chassis.

M5 Threaded Rack Mounting

The first change is a new rack ear fitment for the centre section. This replaces the previous caged nut fitment with threaded M5 holes. This allows the fitment of wider 19" rack equipment into the centre section, such as a full width 10 unit wide 500 Series rack.

Modular Armrest/Front Buffer

The Mk2 Chassis allows the fitment of a new 'modular' front buffer. This is a modular design with soft feel, textured rubber inserts that slot into an extrusion, similar to SSL's Oracle console. This design allows for third party custom panels that can replace the rubber inserts and section dividers with trays, tables etc. fixed into the T-Slot profile that runs under the rubber inserts.

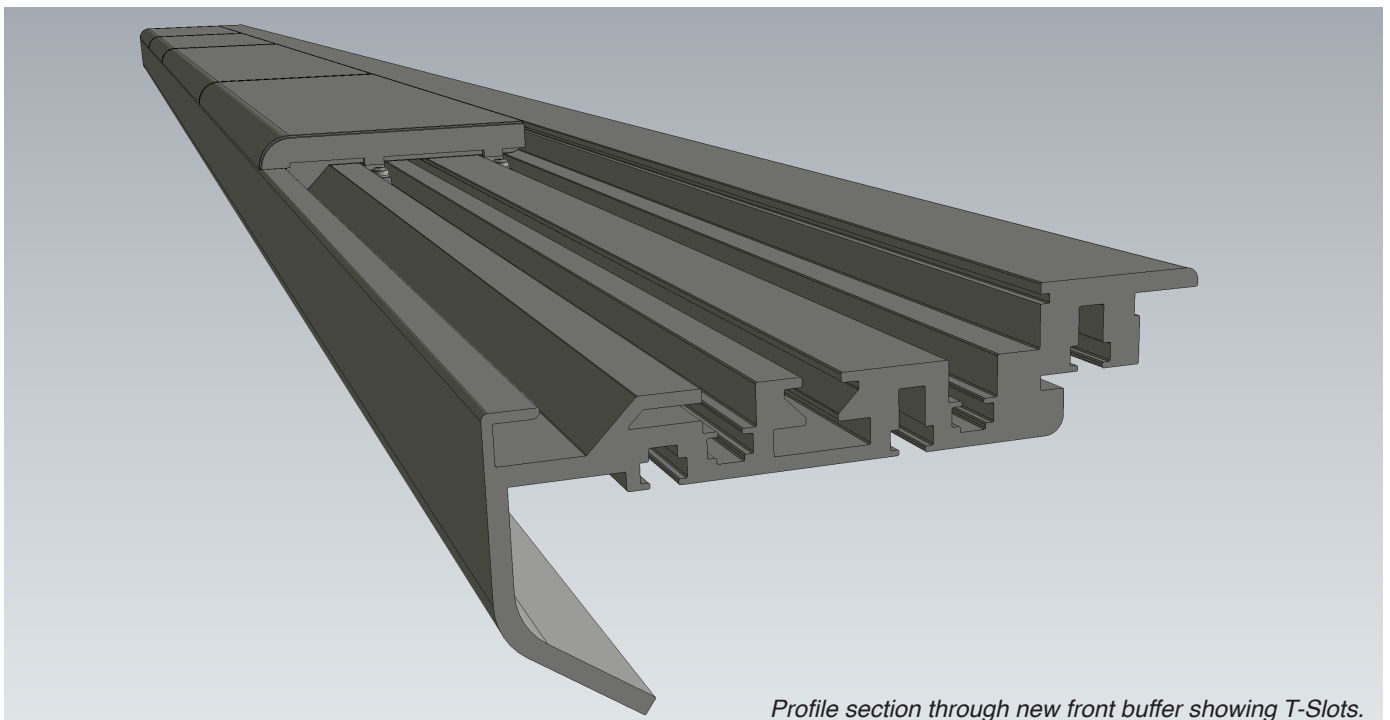

Profile section through new front buffer showing T-Slots.

UF8 Fader Tray Mount Kit - Option

The new chassis also features fixing positions that allow the fitment of an optional retrofit kit to change the position of the Centre Group Faders with a UF8, as shown in the image below.

The kit and upgrade instructions for this modification are available from your SSL distributor.

The retrofit kit part number is: SSL Part# : 624902X8

The kit includes the metalwork and fixings to revise the centre section layout as shown below, including the mounting ears for the UF8. The kit does not include the UF8!



Making Connections - Origin & Origin Evo 16

Rear Connector Locations

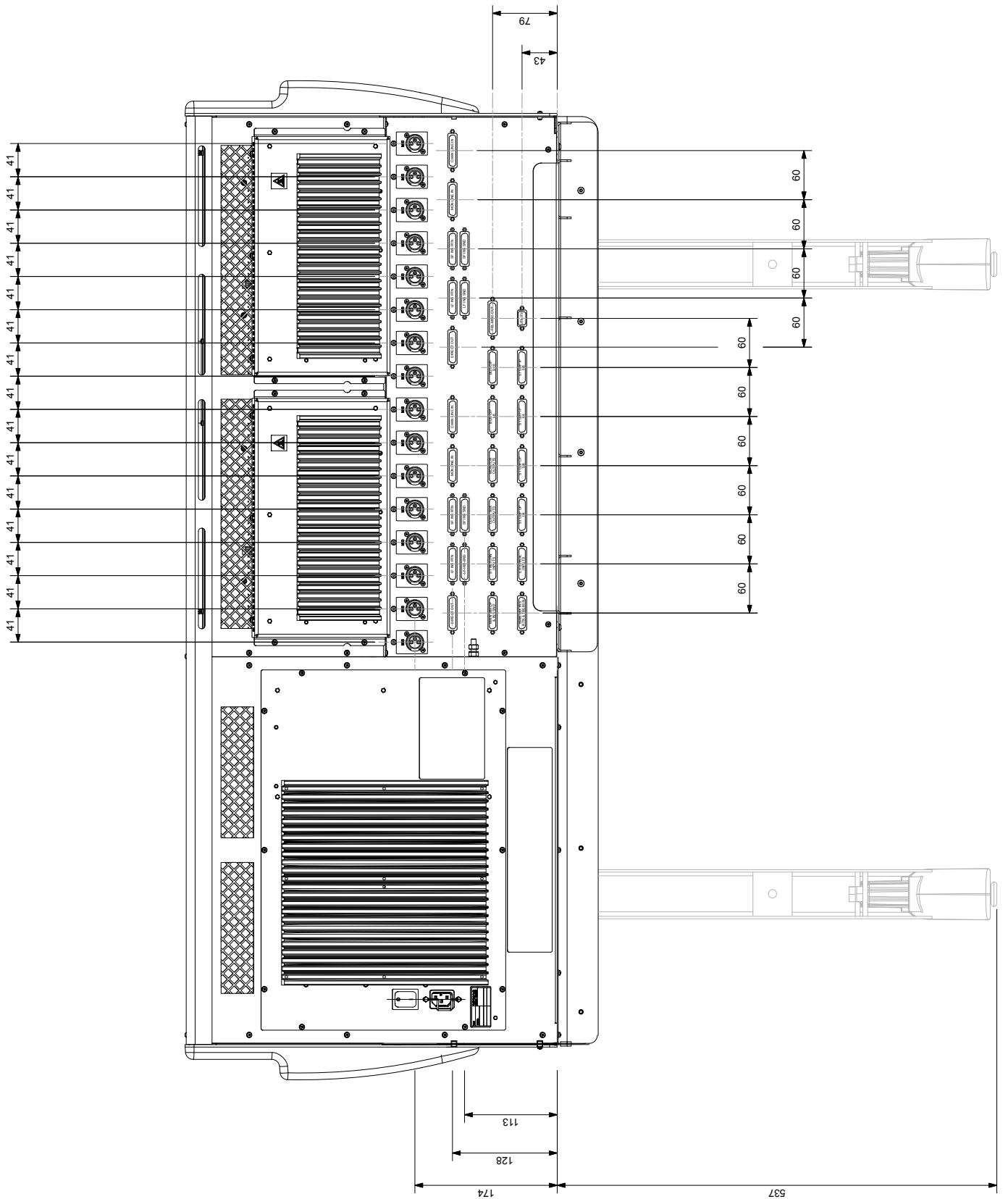

Rear View - Power and Audio Connectors

Location of the main audio and power connections are shown in the diagram below looking towards the rear of the console.

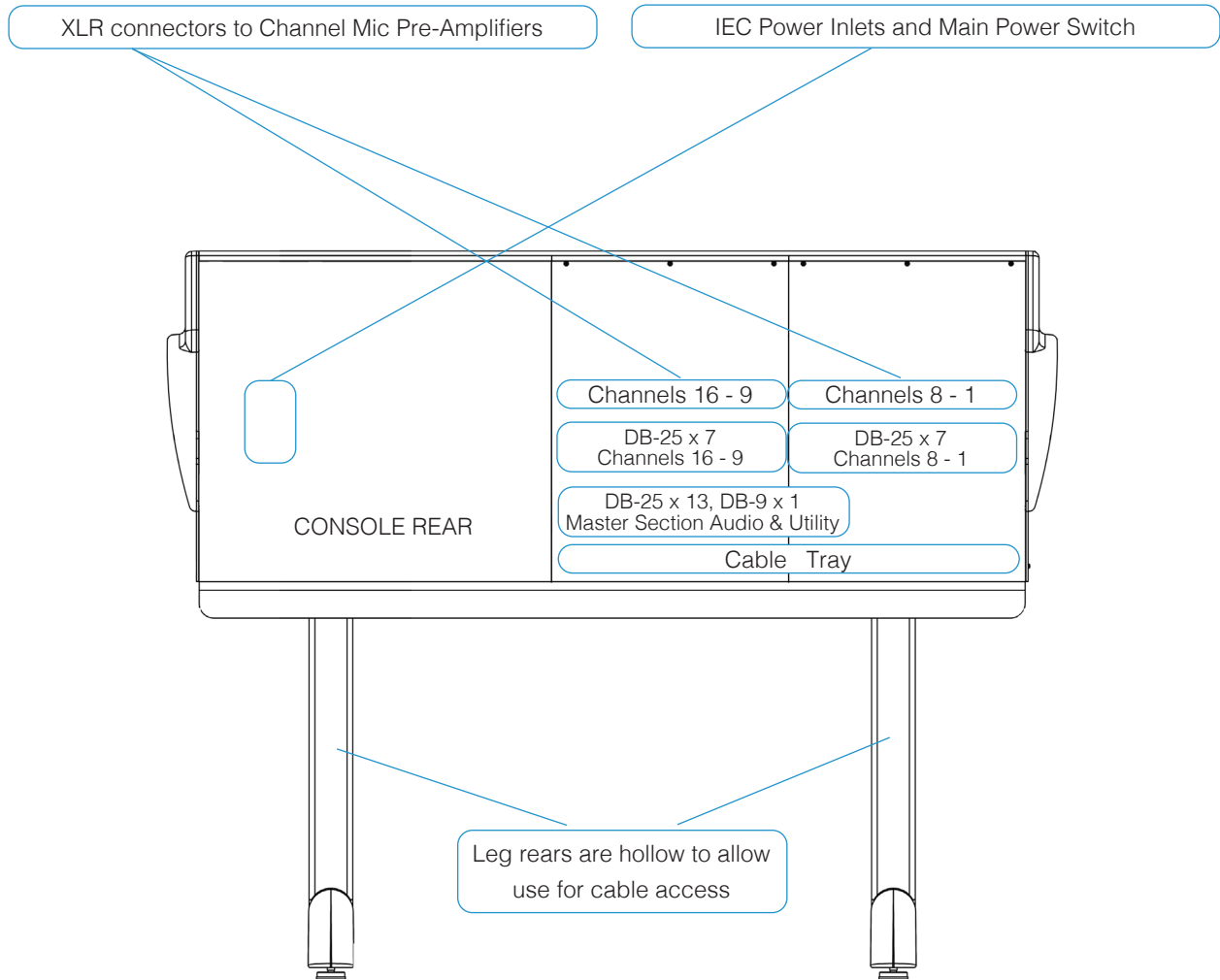

Audio Connector Details

Microphone Inputs

3-pin XLR Female	
Pin	Description
1	0V Chassis
2	Signal +ve (Hot)
3	Signal -ve (Cold)

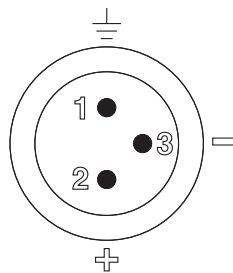

Channel DB-25 Pinouts cont'd

**NOTE: Patch Reference on following tables only applies if using suggested standard patch layout on Page 28

Mon (Monitor) Path Line Inputs

Cct#	25 Way F D-type			Mon Line IN 1-8	Patch	Mon Line IN 9-16	Patch
	Hot	Cold	Scrn		Ref**		Ref**
1	24	12	25	Mon Line IP 1	B17	Mon Line IP 9	B25
2	10	23	11	Mon Line IP 2	B18	Mon Line IP 10	B26
3	21	9	22	Mon Line IP 3	B19	Mon Line IP 11	B27
4	7	20	8	Mon Line IP 4	B20	Mon Line IP 12	B28
5	18	6	19	Mon Line IP 5	B21	Mon Line IP 13	B29
6	4	17	5	Mon Line IP 6	B22	Mon Line IP 14	B30
7	15	3	16	Mon Line IP 7	B23	Mon Line IP 15	B31
8	1	14	2	Mon Line IP 8	B24	Mon Line IP 16	B32

LF (Large Fader) Insert Sends

Cct#	25 Way F D-type			LF Ins Snd 1-8	Patch	LF Ins Snd 9-16	Patch
	Hot	Cold	Scrn		Ref**		Ref**
1	24	12	25	LF Ins Snd 1	C17	LF Ins Snd 9	C25
2	10	23	11	LF Ins Snd 2	C18	LF Ins Snd 10	C26
3	21	9	22	LF Ins Snd 3	C19	LF Ins Snd 11	C27
4	7	20	8	LF Ins Snd 4	C20	LF Ins Snd 12	C28
5	18	6	19	LF Ins Snd 5	C21	LF Ins Snd 13	C29
6	4	17	5	LF Ins Snd 6	C22	LF Ins Snd 14	C30
7	15	3	16	LF Ins Snd 7	C23	LF Ins Snd 15	C31
8	1	14	2	LF Ins Snd 8	C24	LF Ins Snd 16	C32

LF (Large Fader) Insert Returns

Cct#	25 Way F D-type			LF Ins Rtn 1-8	Patch	LF Ins Rtn 9-16	Patch
	Hot	Cold	Scrn		Ref**		Ref**
1	24	12	25	LF Ins Rtn 1	D17	LF Ins Rtn 9	D25
2	10	23	11	LF Ins Rtn 2	D18	LF Ins Rtn 10	D26
3	21	9	22	LF Ins Rtn 3	D19	LF Ins Rtn 11	D27
4	7	20	8	LF Ins Rtn 4	D20	LF Ins Rtn 12	D28
5	18	6	19	LF Ins Rtn 5	D21	LF Ins Rtn 13	D29
6	4	17	5	LF Ins Rtn 6	D22	LF Ins Rtn 14	D30
7	15	3	16	LF Ins Rtn 7	D23	LF Ins Rtn 15	D31
8	1	14	2	LF Ins Rtn 8	D24	LF Ins Rtn 16	D32

SF (Small Fader) Insert Sends

Cct#	25 Way F D-type			SF Ins Snd 1-8	Patch	SF Ins Snd 9-16	Patch
	Hot	Cold	Scrn		Ref**		Ref**
1	24	12	25	SF Ins Snd 1	E1	SF Ins Snd 9	E9
2	10	23	11	SF Ins Snd 2	E2	SF Ins Snd 10	E10
3	21	9	22	SF Ins Snd 3	E3	SF Ins Snd 11	E11
4	7	20	8	SF Ins Snd 4	E4	SF Ins Snd 12	E12
5	18	6	19	SF Ins Snd 5	E5	SF Ins Snd 13	E13
6	4	17	5	SF Ins Snd 6	E6	SF Ins Snd 14	E14
7	15	3	16	SF Ins Snd 7	E7	SF Ins Snd 15	E15
8	1	14	2	SF Ins Snd 8	E8	SF Ins Snd 16	E16

Channel DB-25 Pinouts cont'd

**NOTE: Patch Reference on following tables only applies if using suggested standard patch layout on Page 28

SF (Small Fader) Insert Returns

Cct#	25 Way F D-type			SF Ins Rtn 1-8	Patch	SF Ins Rtn 9-16	Patch
	Hot	Cold	Scrn		Ref**		Ref**
1	24	12	25	SF Ins Rtn 1	F1	SF Ins Rtn 9	F9
2	10	23	11	SF Ins Rtn 2	F2	SF Ins Rtn 10	F10
3	21	9	22	SF Ins Rtn 3	F3	SF Ins Rtn 11	F11
4	7	20	8	SF Ins Rtn 4	F4	SF Ins Rtn 12	F12
5	18	6	19	SF Ins Rtn 5	F5	SF Ins Rtn 13	F13
6	4	17	5	SF Ins Rtn 6	F6	SF Ins Rtn 14	F14
7	15	3	16	SF Ins Rtn 7	F7	SF Ins Rtn 15	F15
8	1	14	2	SF Ins Rtn 8	F8	SF Ins Rtn 16	F16

Channel Direct Outputs

Cct#	25 Way F D-type			Direct Out 1-8	Patch	Direct Out 9-16	Patch
	Hot	Cold	Scrn		Ref**		Ref**
1	24	12	25	Direct Out 1	G1	Direct Out 9	G9
2	10	23	11	Direct Out 2	G2	Direct Out 10	G10
3	21	9	22	Direct Out 3	G3	Direct Out 11	G11
4	7	20	8	Direct Out 4	G4	Direct Out 12	G12
5	18	6	19	Direct Out 5	G5	Direct Out 13	G13
6	4	17	5	Direct Out 6	G6	Direct Out 14	G14
7	15	3	16	Direct Out 7	G7	Direct Out 15	G15
8	1	14	2	Direct Out 8	G8	Direct Out 16	G16

Master Section DB-25 Connectors

The Master Section audio connections are on the rear panel of the console as a group of 13 female DB-25 connectors under the Channel DB-25 Connectors for Channels 9-16.

Each connector uses the common AES59 format for analogue audio DB-25 connectors, the pinout is shown on the right.

The physical layout of the Thirteen connectors is shown below as viewed when looking at the rear of the console.

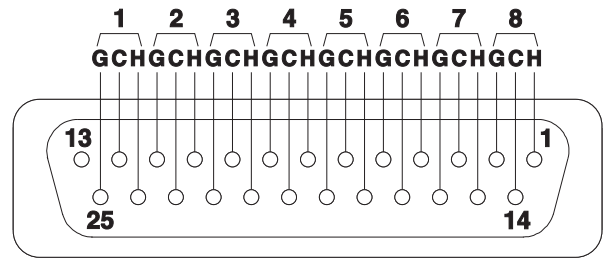

DB-25 Line Level Audio Connector Layout for the Master Section (all female connectors)

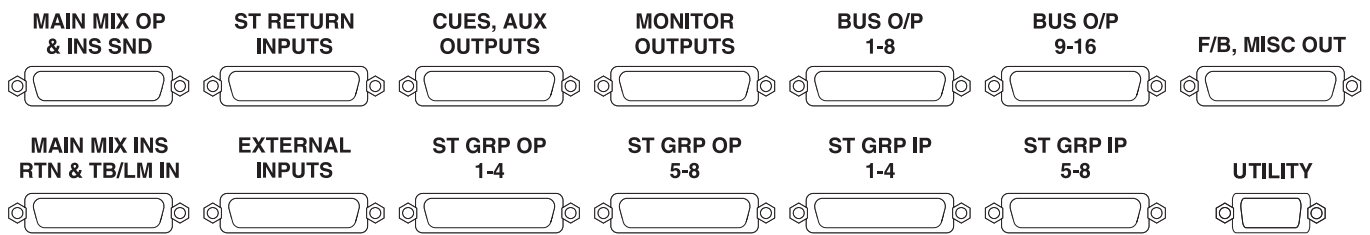

Master Section DB-25 Pinouts

**NOTE: Patch Reference on following tables only applies if using suggested standard patch layout on Page 28

Bus O/P (Bus Outputs)

Cct#	25 Way F D-type			Bus Output 1-8	Patch Ref**	Bus Output 9-16	Patch Ref**
	Hot	Cold	Scrn				
1	24	12	25	Bus Output 1	E17	Bus Output 9	E25
2	10	23	11	Bus Output 2	E18	Bus Output 10	E26
3	21	9	22	Bus Output 3	E19	Bus Output 11	E27
4	7	20	8	Bus Output 4	E20	Bus Output 12	E28
5	18	6	19	Bus Output 5	E21	Bus Output 13	E29
6	4	17	5	Bus Output 6	E22	Bus Output 14	E30
7	15	3	16	Bus Output 7	E23	Bus Output 15	E31
8	1	14	2	Bus Output 8	E24	Bus Output 16	E32

ST GRP IP (Stereo Group Inputs)

Cct#	25 Way F D-type			St Grp IP 1-4	Patch Ref**	St Grp IP 5-8	Patch Ref**
	Hot	Cold	Scrn				
1	24	12	25	St Grp IP 1L	F17	St Grp IP 5L	F25
2	10	23	11	St Grp IP 1R	F18	St Grp IP 5R	F26
3	21	9	22	St Grp IP 2L	F19	St Grp IP 6L	F27
4	7	20	8	St Grp IP 2R	F20	St Grp IP 6R	F28
5	18	6	19	St Grp IP 3L	F21	St Grp IP 7L	F29
6	4	17	5	St Grp IP 3R	F22	St Grp IP 7R	F30
7	15	3	16	St Grp IP 4L	F23	St Grp IP 8L	F31
8	1	14	2	St Grp IP 4R	F24	St Grp IP 8R	F32

Master Section DB-25 Pinouts Cont'd

**NOTE: Patch Reference on following tables only applies if using suggested standard patch layout on Page 28

ST GRP OP (Stereo Group Outputs)

Cct#	25 Way F D-type			St Grp OP 1-4	Patch	St Grp OP 5-8	Patch
	Hot	Cold	Scrn		Ref**		Ref**
1	24	12	25	St Grp OP 1L	G17	St Grp OP 5L	G25
2	10	23	11	St Grp OP 1R	G18	St Grp OP 5R	G26
3	21	9	22	St Grp OP 2L	G19	St Grp OP 6L	G27
4	7	20	8	St Grp OP 2R	G20	St Grp OP 6R	G28
5	18	6	19	St Grp OP 3L	G21	St Grp OP 7L	G29
6	4	17	5	St Grp OP 3R	G22	St Grp OP 7R	G30
7	15	3	16	St Grp OP 4L	G23	St Grp OP 8L	G31
8	1	14	2	St Grp OP 4R	G24	St Grp OP 8R	G32

ST (Stereo) Return Inputs

Cct#	25 Way F D-type			St Rtn IP 1-4	Patch
	Hot	Cold	Scrn		Ref**
1	24	12	25	St Rtn IP 1L	B33
2	10	23	11	St Rtn IP 1R	B34
3	21	9	22	St Rtn IP 2L	B35
4	7	20	8	St Rtn IP 2R	B36
5	18	6	19	St Rtn IP 3L	B37
6	4	17	5	St Rtn IP 3R	B38
7	15	3	16	St Rtn IP 4L	B39
8	1	14	2	St Rtn IP 4R	B40

Monitor Outputs

Cct#	25 Way F D-type			Monitor	Patch
	Hot	Cold	Scrn	Outputs	Ref**
1	24	12	25	Main L	A41
2	10	23	11	Main R	A42
3	21	9	22	Alt Mon 1L	A43
4	7	20	8	Alt Mon 1R	A44
5	18	6	19	Alt Mon 2L	A45
6	4	17	5	Alt Mon 2R	A46
7	15	3	16	Alt Mon 3L	A47
8	1	14	2	Alt Mon 3R	A48

External Inputs (and TB/Lstn Mic Parallel IPs)

Cct#	25 Way F D-type			External IP 1-3	Patch
	Hot	Cold	Scrn		Ref**
1	24	12	25	External IP 1 L	D33
2	10	23	11	External IP 1 R	D34
3	21	9	22	External IP 2 L	D35
4	7	20	8	External IP 2 R	D36
5	18	6	19	External IP 3 L	D37
6	4	17	5	External IP 3 R	D38
7	15	3	16	Tb Mic In Parallel	D39
8	1	14	2	Listn Mic In lel	D40

Cue/Aux Outputs

Cct#	25 Way F D-type			Cue A,B Aux 1-4	Patch
	Hot	Cold	Scrn	Outputs	Ref**
1	24	12	25	St Cue OP A L	C41
2	10	23	11	St Cue OP A R	C42
3	21	9	22	St Cue OP B L	C43
4	7	20	8	St Cue OP B R	C44
5	18	6	19	Aux Output 1	C45
6	4	17	5	Aux Output 2	C46
7	15	3	16	Aux Output 3	C47
8	1	14	2	Aux Output 4	C48

Main Mix (Bus) Outputs and (Mix Bus) Insert Send

Cct#	25 Way F D-type			Main OPs	Patch
	Hot	Cold	Scrn		Ref**
1	24	12	25	Mix Ins Snd L	E33
2	10	23	11	Mix Ins Snd R	E34
3	21	9	22	Mix OP L	E35
4	7	20	8	Mix OP R	E36
5	18	6	19	N/C	E37
6	4	17	5	N/C	E38
7	15	3	16	N/C	E39
8	1	14	2	Ext TB Out	E40

F/B (Foldback, Studio) and Misc Outputs

Cct#	25 Way F D-type			Osc, Foldback & Studio LS	Patch
	Hot	Cold	Scrn	Ref**	
1	24	12	25	Oscillator Out	E41
2	10	23	11	Listen Mic Out	E42
3	21	9	22	Foldback Out AL	E43
4	7	20	8	Foldback Out AR	E44
5	18	6	19	Foldback Out BL	E45
6	4	17	5	Foldback Out BR	E46
7	15	3	16	Studio L	E47
8	1	14	2	Studio R	E48

Master Section DB-25 Pinouts Cont'd

**NOTE: Patch Reference on following tables only applies if using suggested standard patch layout on Page 28

Mix Bus INS RTN (Insert Return) and TB/LM (Talkback/Listen Mic) Line Inputs

Cct#	25 Way F D-type			Main Ins Rtn	Patch
	Hot	Cold	Scrn	Talkback/Listen	Ref**
1	24	12	25	Main Ins Rtn L	F33
2	10	23	11	Main Ins Rtn R	F34
3	21	9	22	N/C	F35
4	7	20	8	N/C	F36
5	18	6	19	TB Line In	F37
6	4	17	5	Listen Line In	F38
7	15	3	16	N/C	F39
8	1	14	2	N/C	F40

UTILITY

Pin	9-Way F D-type
	Red Light Relay
1	Normally Open Contact R1
2	Common
3	Normally Closed Contact R1
4	Normally Open Contact R2
5	Common
6	Normally Closed Contact R2
7	N/C
8	N/C
9	N/C

R1 and R2 are separate relays, both operated by the Red Light Switch

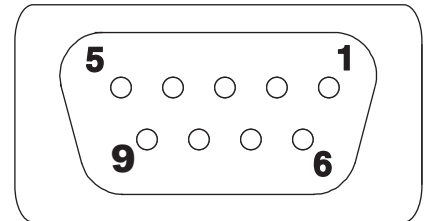

Suggested Patchbay Layout - Origin & Origin Evo 16

Patchbay Normalising Suggestions

In the suggested patchbay layout below, the upper rows are configured to be half-normalled to the lower rows for each 1U pair of patchrows. The layout is designed to use DB-25 to Bantam TT patchbays, such as the Neutrik NPPA-TT-SD25 or the Signex CPT96D25. With these patchrows, standard AES59 compatible DB-25 to DB-25 cables can be used to connect between console and patchbay,

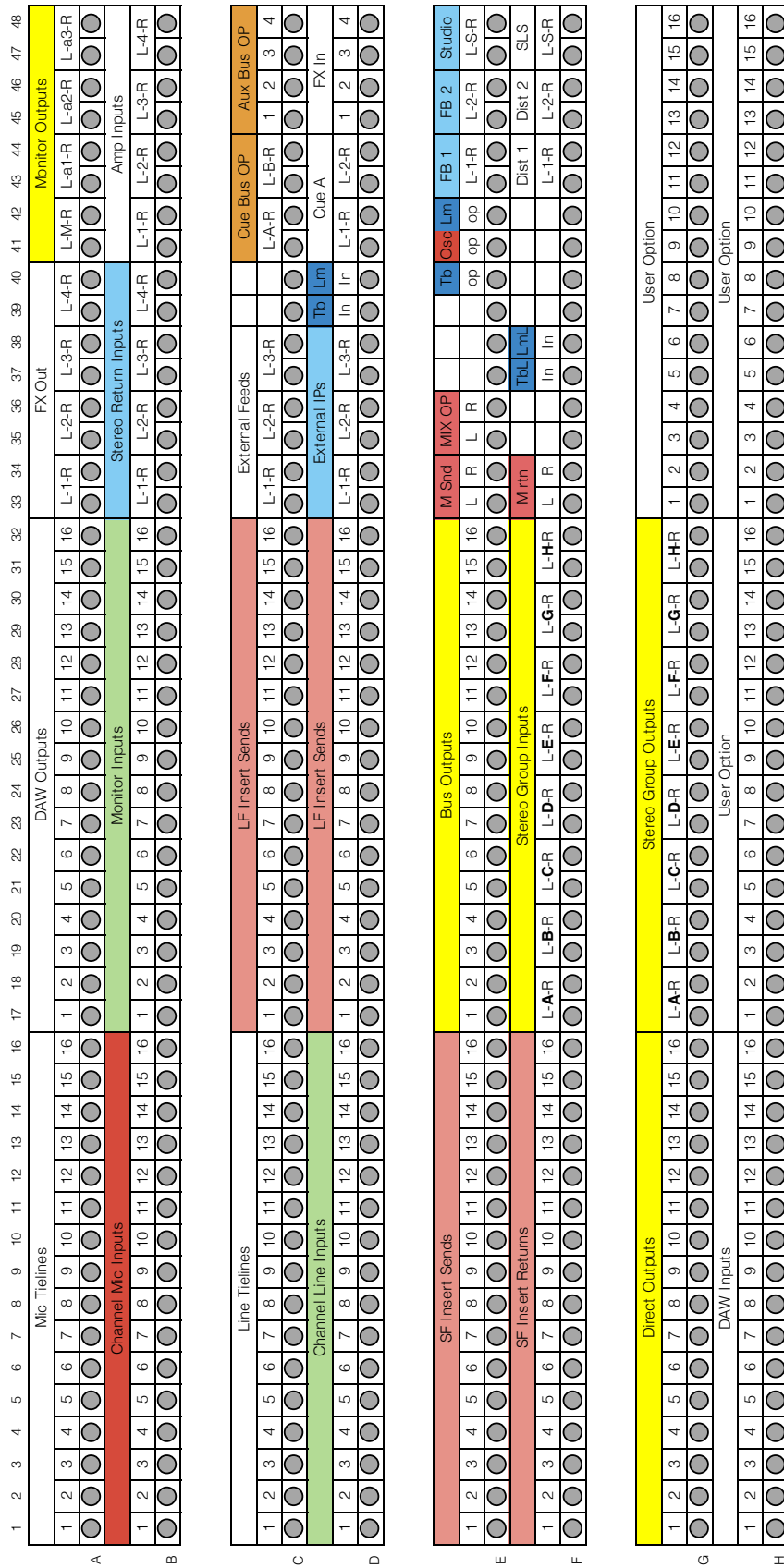

Coloured Idents are DB-25 (XLR for Mics) to/from Console Connector Panel(s)

Making Connections - Origin & Origin Evo 32

Rear Connector Locations

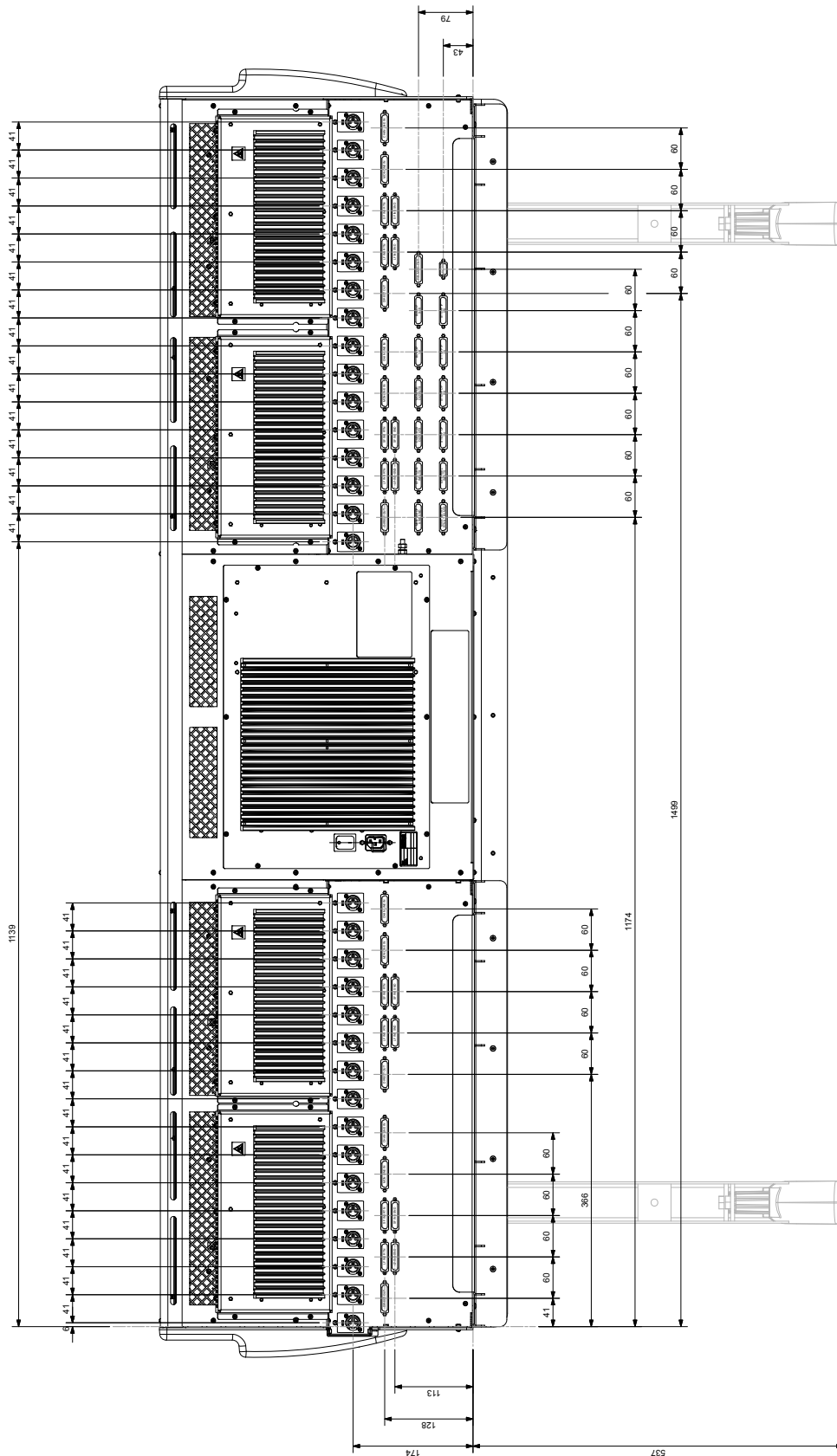

Rear View - Power and Audio Connectors

Location of the main audio and power connections are shown in the diagram below looking towards the rear of the console.

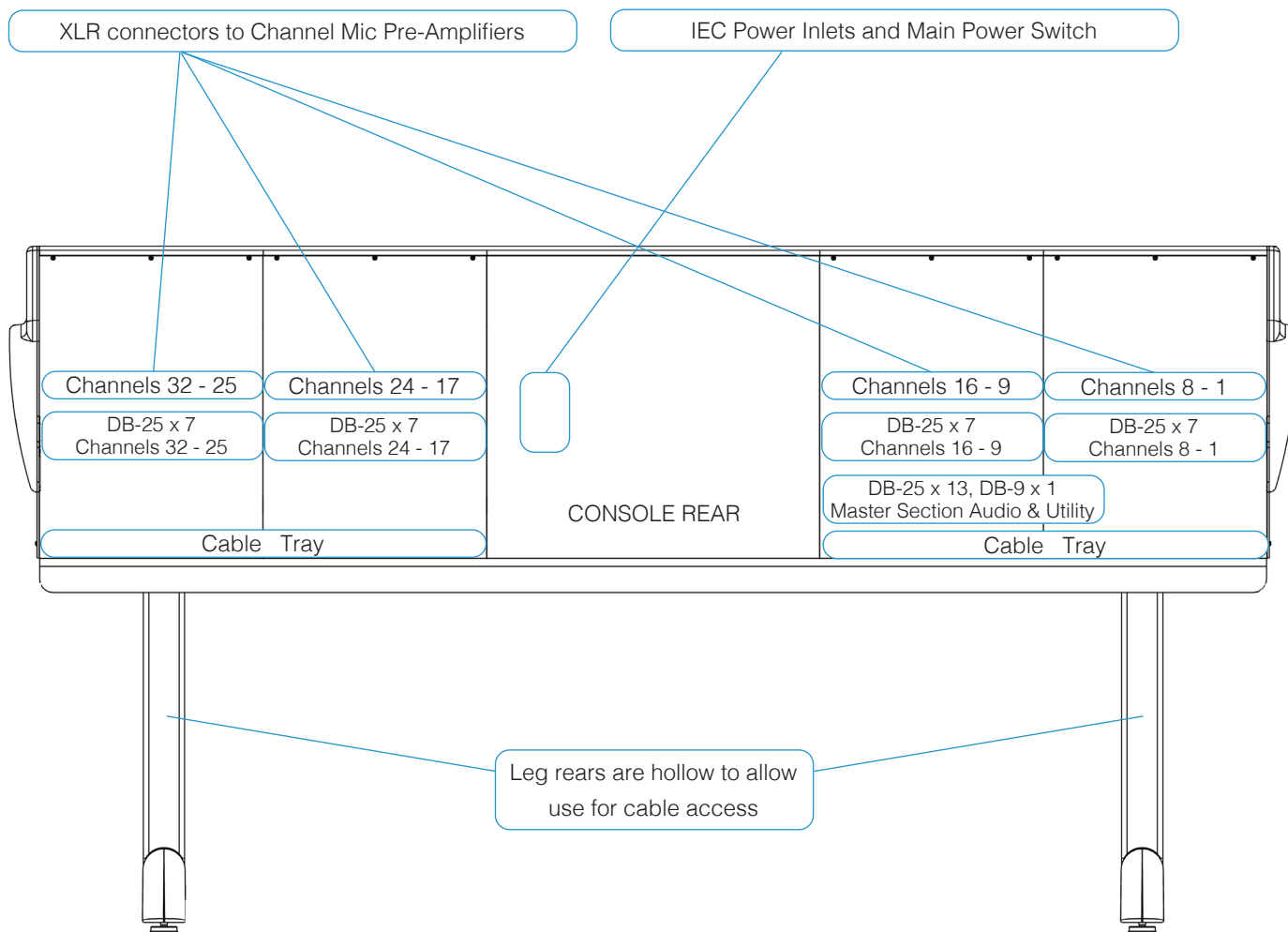

Audio Connector Details

Microphone Inputs

3-pin XLR Female	
Pin	Description
1	0V Chassis
2	Signal +ve (Hot)
3	Signal -ve (Cold)

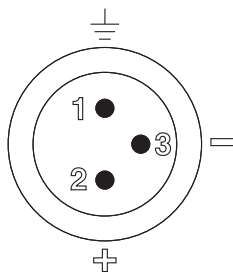

Chan (Channel) Path Mic XLR Inputs

		Patch			Patch			Patch			Patch
XLR#	Chan Mic IN 1-8	Ref**	XLR#	Chan Mic IN 9-16	Ref**	XLR#	Chan Mic IN 17-24	Ref**	XLR#	Chan Mic IN 25-32	Ref**
1	Chan Mic IP 1	B1	9	Chan Mic IP 9	B9	17	Chan Mic IP 17	B17	25	Chan Mic IP 25	B25
2	Chan Mic IP 2	B2	10	Chan Mic IP 10	B10	18	Chan Mic IP 18	B18	26	Chan Mic IP 26	B26
3	Chan Mic IP 3	B3	11	Chan Mic IP 11	B11	19	Chan Mic IP 19	B19	27	Chan Mic IP 27	B27
4	Chan Mic IP 4	B4	12	Chan Mic IP 12	B12	20	Chan Mic IP 20	B20	28	Chan Mic IP 28	B28
5	Chan Mic IP 5	B5	13	Chan Mic IP 13	B13	21	Chan Mic IP 21	B21	29	Chan Mic IP 29	B29
6	Chan Mic IP 6	B6	14	Chan Mic IP 14	B14	22	Chan Mic IP 22	B22	30	Chan Mic IP 30	B30
7	Chan Mic IP 7	B7	15	Chan Mic IP 15	B15	23	Chan Mic IP 23	B23	31	Chan Mic IP 31	B31
8	Chan Mic IP 8	B8	16	Chan Mic IP 16	B16	24	Chan Mic IP 24	B24	32	Chan Mic IP 32	B32

Channel DB-25 Connectors

The Large Fader and Small Fader Path line level audio connections are on the rear panel of the console. Each connector set of seven DB-25 connectors carries the fully balanced audio for eight channels, laid out on the rear of the console as shown on the previous page, so for 32 channels there are four sets of seven DB-25 connectors. Each connector uses the common AES59 format for analogue audio DB-25 connectors, the pinout is shown on the right.

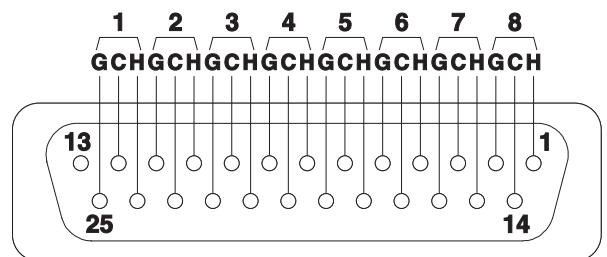

The physical layout of the seven connectors is shown below as viewed when looking at the rear of the console.

DB-25 Line Level Audio Connectors for Channels 1-8, 9-16, 17-24, 25-32 (4 sets of seven female connectors)

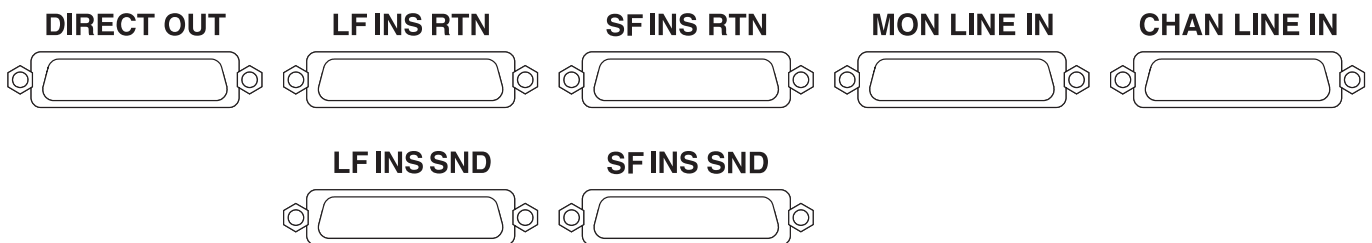

Channel DB-25 Pinouts

**NOTE: Patch Reference on following tables only applies if using suggested standard patch layout on Page 37

Chan (Channel) Path Line Inputs

	25 Way F D-type				Patch		Patch		Patch		Patch
Cct#	Hot	Cold	Scrn	Chan Line IN 1-8	Ref**	Chan Line IN 9-16	Ref**	Chan Line IN 17-24	Ref**	Chan Line IN 25-32	Ref**
1	24	12	25	Ch Line IP 1	D1	Ch Line IP 9	D9	Ch Line IP 17	D17	Ch Line IP 25	D25
2	10	23	11	Ch Line IP 2	D2	Ch Line IP 10	D10	Ch Line IP 18	D18	Ch Line IP 26	D26
3	21	9	22	Ch Line IP 3	D3	Ch Line IP 11	D11	Ch Line IP 19	D19	Ch Line IP 27	D27
4	7	20	8	Ch Line IP 4	D4	Ch Line IP 12	D12	Ch Line IP 20	D20	Ch Line IP 28	D28
5	18	6	19	Ch Line IP 5	D5	Ch Line IP 13	D13	Ch Line IP 21	D21	Ch Line IP 29	D29
6	4	17	5	Ch Line IP 6	D6	Ch Line IP 14	D14	Ch Line IP 22	D22	Ch Line IP 30	D30
7	15	3	16	Ch Line IP 7	D7	Ch Line IP 15	D15	Ch Line IP 23	D23	Ch Line IP 31	D31
8	1	14	2	Ch Line IP 8	D8	Ch Line IP 16	D16	Ch Line IP 24	D24	Ch Line IP 32	D32

Channel DB-25 Pinouts cont'd

**NOTE: Patch Reference on following tables only applies if using suggested standard patch layout on Page 37

Mon (Monitor) Path Line Inputs

Cct#	25 Way F D-type			Mon Line IN 1-8	Patch	Mon Line IN 9-16	Patch	Mon Line IN 17-24	Patch	Mon Line IN 25-32	Patch
	Hot	Cold	Scrn		Ref**		Ref**		Ref**		Ref**
1	24	12	25	Mon Line IP 1	F1	Mon Line IP 9	F9	Mon Line IP 17	F17	Mon Line IP 25	F25
2	10	23	11	Mon Line IP 2	F2	Mon Line IP 10	F10	Mon Line IP 18	F18	Mon Line IP 26	F26
3	21	9	22	Mon Line IP 3	F3	Mon Line IP 11	F11	Mon Line IP 19	F19	Mon Line IP 27	F27
4	7	20	8	Mon Line IP 4	F4	Mon Line IP 12	F12	Mon Line IP 20	F20	Mon Line IP 28	F28
5	18	6	19	Mon Line IP 5	F5	Mon Line IP 13	F13	Mon Line IP 21	F21	Mon Line IP 29	F29
6	4	17	5	Mon Line IP 6	F6	Mon Line IP 14	F14	Mon Line IP 22	F22	Mon Line IP 30	F30
7	15	3	16	Mon Line IP 7	F7	Mon Line IP 15	F15	Mon Line IP 23	F23	Mon Line IP 31	F31
8	1	14	2	Mon Line IP 8	F8	Mon Line IP 16	F16	Mon Line IP 24	F24	Mon Line IP 32	F32

LF (Large Fader) Insert Sends

Cct#	25 Way F D-type			LF Ins Snd 1-8	Patch	LF Ins Snd 9-16	Patch	LF Ins Snd 17-24	Patch	LF Ins Snd 25-32	Patch
	Hot	Cold	Scrn		Ref**		Ref**		Ref**		Ref**
1	24	12	25	LF Ins Snd 1	G1	LF Ins Snd 9	G9	LF Ins Snd 17	G17	LF Ins Snd 25	G25
2	10	23	11	LF Ins Snd 2	G2	LF Ins Snd 10	G10	LF Ins Snd 18	G18	LF Ins Snd 26	G26
3	21	9	22	LF Ins Snd 3	G3	LF Ins Snd 11	G11	LF Ins Snd 19	G19	LF Ins Snd 27	G27
4	7	20	8	LF Ins Snd 4	G4	LF Ins Snd 12	G12	LF Ins Snd 20	G20	LF Ins Snd 28	G28
5	18	6	19	LF Ins Snd 5	G5	LF Ins Snd 13	G13	LF Ins Snd 21	G21	LF Ins Snd 29	G29
6	4	17	5	LF Ins Snd 6	G6	LF Ins Snd 14	G14	LF Ins Snd 22	G22	LF Ins Snd 30	G30
7	15	3	16	LF Ins Snd 7	G7	LF Ins Snd 15	G15	LF Ins Snd 23	G23	LF Ins Snd 31	G31
8	1	14	2	LF Ins Snd 8	G8	LF Ins Snd 16	G16	LF Ins Snd 24	G24	LF Ins Snd 32	G32

LF (Large Fader) Insert Returns

Cct#	25 Way F D-type			LF Ins Rtn 1-8	Patch	LF Ins Rtn 9-16	Patch	LF Ins Rtn 17-24	Patch	LF Ins Rtn 25-32	Patch
	Hot	Cold	Scrn		Ref**		Ref**		Ref**		Ref**
1	24	12	25	LF Ins Rtn 1	H1	LF Ins Rtn 9	H9	LF Ins Rtn 17	H17	LF Ins Rtn 25	H25
2	10	23	11	LF Ins Rtn 2	H2	LF Ins Rtn 10	H10	LF Ins Rtn 18	H18	LF Ins Rtn 26	H26
3	21	9	22	LF Ins Rtn 3	H3	LF Ins Rtn 11	H11	LF Ins Rtn 19	H19	LF Ins Rtn 27	H27
4	7	20	8	LF Ins Rtn 4	H4	LF Ins Rtn 12	H12	LF Ins Rtn 20	H20	LF Ins Rtn 28	H28
5	18	6	19	LF Ins Rtn 5	H5	LF Ins Rtn 13	H13	LF Ins Rtn 21	H21	LF Ins Rtn 29	H29
6	4	17	5	LF Ins Rtn 6	H6	LF Ins Rtn 14	H14	LF Ins Rtn 22	H22	LF Ins Rtn 30	H30
7	15	3	16	LF Ins Rtn 7	H7	LF Ins Rtn 15	H15	LF Ins Rtn 23	H23	LF Ins Rtn 31	H31
8	1	14	2	LF Ins Rtn 8	H8	LF Ins Rtn 16	H16	LF Ins Rtn 24	H24	LF Ins Rtn 32	H32

SF (Small Fader) Insert Sends

Cct#	25 Way F D-type			SF Ins Snd 1-8	Patch	SF Ins Snd 9-16	Patch	SF Ins Snd 17-24	Patch	SF Ins Snd 25-32	Patch
	Hot	Cold	Scrn		Ref**		Ref**		Ref**		Ref**
1	24	12	25	SF Ins Snd 1	I1	SF Ins Snd 9	I9	SF Ins Snd 17	I17	SF Ins Snd 25	I25
2	10	23	11	SF Ins Snd 2	I2	SF Ins Snd 10	I10	SF Ins Snd 18	I18	SF Ins Snd 26	I26
3	21	9	22	SF Ins Snd 3	I3	SF Ins Snd 11	I11	SF Ins Snd 19	I19	SF Ins Snd 27	I27
4	7	20	8	SF Ins Snd 4	I4	SF Ins Snd 12	I12	SF Ins Snd 20	I20	SF Ins Snd 28	I28
5	18	6	19	SF Ins Snd 5	I5	SF Ins Snd 13	I13	SF Ins Snd 21	I21	SF Ins Snd 29	I29
6	4	17	5	SF Ins Snd 6	I6	SF Ins Snd 14	I14	SF Ins Snd 22	I22	SF Ins Snd 30	I30
7	15	3	16	SF Ins Snd 7	I7	SF Ins Snd 15	I15	SF Ins Snd 23	I23	SF Ins Snd 31	I31
8	1	14	2	SF Ins Snd 8	I8	SF Ins Snd 16	I16	SF Ins Snd 24	I24	SF Ins Snd 32	I32

Channel DB-25 Pinouts cont'd

**NOTE: Patch Reference on following tables only applies if using suggested standard patch layout on Page 37

SF (Small Fader) Insert Returns

Cct#	25 Way F D-type			SF Ins Rtn 1-8	Patch	SF Ins Rtn 9-16	Patch	SF Ins Rtn 17-24	Patch	SF Ins Rtn 25-32	Patch
	Hot	Cold	Scrn		Ref**		Ref**		Ref**		Ref**
1	24	12	25	SF Ins Rtn 1	J1	SF Ins Rtn 9	J9	SF Ins Rtn 17	J17	SF Ins Rtn 25	J25
2	10	23	11	SF Ins Rtn 2	J2	SF Ins Rtn 10	J10	SF Ins Rtn 18	J18	SF Ins Rtn 26	J26
3	21	9	22	SF Ins Rtn 3	J3	SF Ins Rtn 11	J11	SF Ins Rtn 19	J19	SF Ins Rtn 27	J27
4	7	20	8	SF Ins Rtn 4	J4	SF Ins Rtn 12	J12	SF Ins Rtn 20	J20	SF Ins Rtn 28	J28
5	18	6	19	SF Ins Rtn 5	J5	SF Ins Rtn 13	J13	SF Ins Rtn 21	J21	SF Ins Rtn 29	J29
6	4	17	5	SF Ins Rtn 6	J6	SF Ins Rtn 14	J14	SF Ins Rtn 22	J22	SF Ins Rtn 30	J30
7	15	3	16	SF Ins Rtn 7	J7	SF Ins Rtn 15	J15	SF Ins Rtn 23	J23	SF Ins Rtn 31	J31
8	1	14	2	SF Ins Rtn 8	J8	SF Ins Rtn 16	J16	SF Ins Rtn 24	J24	SF Ins Rtn 32	J32

Channel Direct Outputs

Cct#	25 Way F D-type			Direct Out 1-8	Patch	Direct Out 9-16	Patch	Direct Out 17-24	Patch	Direct Out 25-32	Patch
	Hot	Cold	Scrn		Ref**		Ref**		Ref**		Ref**
1	24	12	25	Direct Out 1	K1	Direct Out 9	K9	Direct Out 17	K17	Direct Out 25	K25
2	10	23	11	Direct Out 2	K2	Direct Out 10	K10	Direct Out 18	K18	Direct Out 26	K26
3	21	9	22	Direct Out 3	K3	Direct Out 11	K11	Direct Out 19	K19	Direct Out 27	K27
4	7	20	8	Direct Out 4	K4	Direct Out 12	K12	Direct Out 20	K20	Direct Out 28	K28
5	18	6	19	Direct Out 5	K5	Direct Out 13	K13	Direct Out 21	K21	Direct Out 29	K29
6	4	17	5	Direct Out 6	K6	Direct Out 14	K14	Direct Out 22	K22	Direct Out 30	K30
7	15	3	16	Direct Out 7	K7	Direct Out 15	K15	Direct Out 23	K23	Direct Out 31	K31
8	1	14	2	Direct Out 8	K8	Direct Out 16	K16	Direct Out 24	K24	Direct Out 32	K32

Master Section DB-25 Connectors

The Master Section audio connections are on the rear panel of the console as a group of 13 female DB-25 connectors under the Channel DB-25 Connectors for Channels 9-16.

Each connector uses the common AES59 format for analogue audio DB-25 connectors, the pinout is shown on the right.

The physical layout of the Thirteen connectors is shown below as viewed when looking at the rear of the console.

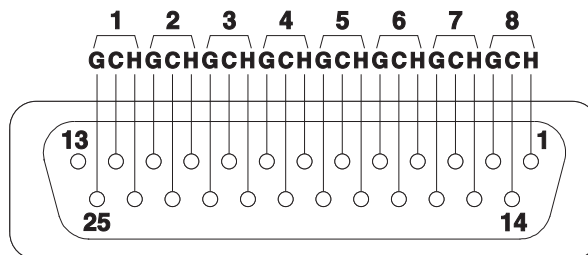

DB-25 Line Level Audio Connector Layout for the Master Section (all female connectors)

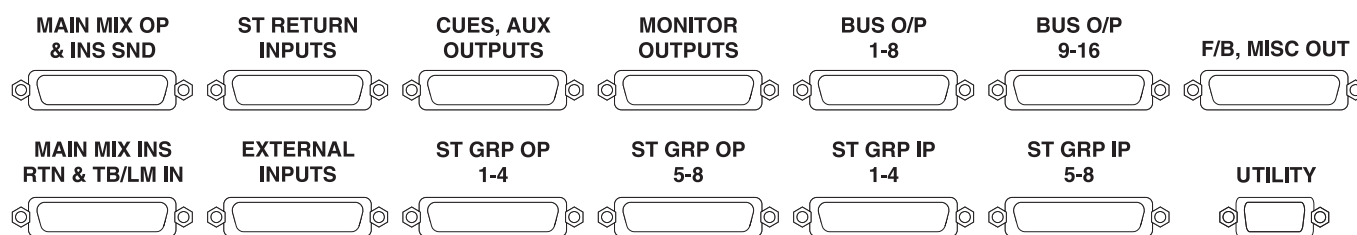

Master Section DB-25 Pinouts

**NOTE: Patch Reference on following tables only applies if using suggested standard patch layout on Page 37

Bus O/P (Bus Outputs)

Cct#	25 Way F D-type			Bus Output 1-8	Patch Ref**	Bus Output 9-16	Patch Ref**
	Hot	Cold	Scrn				
1	24	12	25	Bus Output 1	A33	Bus Output 9	A41
2	10	23	11	Bus Output 2	A34	Bus Output 10	A42
3	21	9	22	Bus Output 3	A35	Bus Output 11	A43
4	7	20	8	Bus Output 4	A36	Bus Output 12	A44
5	18	6	19	Bus Output 5	A37	Bus Output 13	A45
6	4	17	5	Bus Output 6	A38	Bus Output 14	A46
7	15	3	16	Bus Output 7	A39	Bus Output 15	A47
8	1	14	2	Bus Output 8	A40	Bus Output 16	A48

ST GRP IP (Stereo Group Inputs)

Cct#	25 Way F D-type			St Grp IP 1-4	Patch Ref**	St Grp IP 5-8	Patch Ref**
	Hot	Cold	Scrn				
1	24	12	25	St Grp IP 1L	B33	St Grp IP 5L	B41
2	10	23	11	St Grp IP 1R	B34	St Grp IP 5R	B42
3	21	9	22	St Grp IP 2L	B35	St Grp IP 6L	B43
4	7	20	8	St Grp IP 2R	B36	St Grp IP 6R	B44
5	18	6	19	St Grp IP 3L	B37	St Grp IP 7L	B45
6	4	17	5	St Grp IP 3R	B38	St Grp IP 7R	B46
7	15	3	16	St Grp IP 4L	B39	St Grp IP 8L	B47
8	1	14	2	St Grp IP 4R	B40	St Grp IP 8R	B48

Master Section DB-25 Pinouts Cont'd

**NOTE: Patch Reference on following tables only applies if using suggested standard patch layout on Page 37

ST GRP OP (Stereo Group Outputs)

Cct#	25 Way F D-type			St Grp OP 1-4	Patch Ref**	St Grp OP 5-8	Patch Ref**
	Hot	Cold	Scrn				
1	24	12	25	St Grp OP 1L	C33	St Grp OP 5L	C41
2	10	23	11	St Grp OP 1R	C34	St Grp OP 5R	C42
3	21	9	22	St Grp OP 2L	C35	St Grp OP 6L	C43
4	7	20	8	St Grp OP 2R	C36	St Grp OP 6R	C44
5	18	6	19	St Grp OP 3L	C37	St Grp OP 7L	C45
6	4	17	5	St Grp OP 3R	C38	St Grp OP 7R	C46
7	15	3	16	St Grp OP 4L	C39	St Grp OP 8L	C47
8	1	14	2	St Grp OP 4R	C40	St Grp OP 8R	C48

ST (Stereo) Return Inputs

Cct#	25 Way F D-type			St Rtn IP 1-4	Patch Ref**
	Hot	Cold	Scrn		
1	24	12	25	St Rtn IP 1L	H33
2	10	23	11	St Rtn IP 1R	H34
3	21	9	22	St Rtn IP 2L	H35
4	7	20	8	St Rtn IP 2R	H36
5	18	6	19	St Rtn IP 3L	H37
6	4	17	5	St Rtn IP 3R	H38
7	15	3	16	St Rtn IP 4L	H39
8	1	14	2	St Rtn IP 4R	H40

Monitor Outputs

Cct#	25 Way F D-type			Monitor Outputs	Patch Ref**
	Hot	Cold	Scrn		
1	24	12	25	Main L	G41
2	10	23	11	Main R	G42
3	21	9	22	Alt Mon 1L	G43
4	7	20	8	Alt Mon 1R	G44
5	18	6	19	Alt Mon 2L	G45
6	4	17	5	Alt Mon 2R	G46
7	15	3	16	Alt Mon 3L	G47
8	1	14	2	Alt Mon 3R	G48

External Inputs (and TB/Lstn Mic Parallel IPs)

Cct#	25 Way F D-type			External IP 1-3	Patch Ref**
	Hot	Cold	Scrn		
1	24	12	25	External IP 1 L	J33
2	10	23	11	External IP 1 R	J34
3	21	9	22	External IP 2 L	J35
4	7	20	8	External IP 2 R	J36
5	18	6	19	External IP 3 L	J37
6	4	17	5	External IP 3 R	J38
7	15	3	16	Tb Mic In Parallel	J39
8	1	14	2	Listn Mic In el	J40

Cue/Aux Outputs

Cct#	25 Way F D-type			Cue A,B Aux 1-4 Outputs	Patch Ref**
	Hot	Cold	Scrn		
1	24	12	25	St Cue OP A L	I41
2	10	23	11	St Cue OP A R	I42
3	21	9	22	St Cue OP B L	I43
4	7	20	8	St Cue OP B R	I44
5	18	6	19	Aux Output 1	I45
6	4	17	5	Aux Output 2	I46
7	15	3	16	Aux Output 3	I47
8	1	14	2	Aux Output 4	I48

Main Mix (Bus) Outputs and (Mix Bus) Insert Send

Cct#	25 Way F D-type			Main OPs	Patch Ref**
	Hot	Cold	Scrn		
1	24	12	25	Mix Ins Snd L	K33
2	10	23	11	Mix Ins Snd R	K34
3	21	9	22	Mix OP L	K35
4	7	20	8	Mix OP R	K36
5	18	6	19	N/C	K37
6	4	17	5	N/C	K38
7	15	3	16	N/C	K39
8	1	14	2	Ext TB Out	K40

F/B (Foldback, Studio) and Misc Outputs

Cct#	25 Way F D-type			Osc, Foldback & Studio LS	Patch Ref**
	Hot	Cold	Scrn		
1	24	12	25	Oscillator Out	K41
2	10	23	11	Listen Mic Out	K42
3	21	9	22	Foldback Out AL	K43
4	7	20	8	Foldback Out AR	K44
5	18	6	19	Foldback Out BL	K45
6	4	17	5	Foldback Out BR	K46
7	15	3	16	Studio L	K47
8	1	14	2	Studio R	K48

Master Section DB-25 Pinouts Cont'd

**NOTE: Patch Reference on following tables only applies if using suggested standard patch layout on Page 37

Mix Bus INS RTN (Insert Return) and TB/LM (Talkback/Listen Mic) Line Inputs

Cct#	25 Way F D-type			Main Ins Rtn	Patch
	Hot	Cold	Scrn	Talkback/Listen	Ref**
1	24	12	25	Main Ins Rtn L	L33
2	10	23	11	Main Ins Rtn R	L34
3	21	9	22	N/C	L35
4	7	20	8	N/C	L36
5	18	6	19	TB Line In	L37
6	4	17	5	Listen Line In	L38
7	15	3	16	N/C	L39
8	1	14	2	N/C	L40

UTILITY

Pin	9-Way F D-type
	Red Light Relay
1	Normally Open Contact R1
2	Common
3	Normally Closed Contact R1
4	Normally Open Contact R2
5	Common
6	Normally Closed Contact R2
7	N/C
8	N/C
9	N/C

R1 and R2 are separate relays, both operated by the Red Light Switch

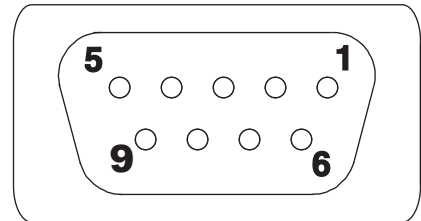

Suggested Patchbay Layout - Origin & Origin Evo 32

Patchbay Normalising Suggestions

In the suggested patchbay layout below, the upper rows are configured to be half-normalled to the lower rows for each 1U pair of patchrows. The layout is designed to use DB-25 to Bantam TT patchbays, such as the Neutrik NPPA-TT-SD25 or the Signex CPT96D25. With these patchrows, standard AES59 compatible DB-25 to DB-25 cables can be used to connect between console and patchbay.

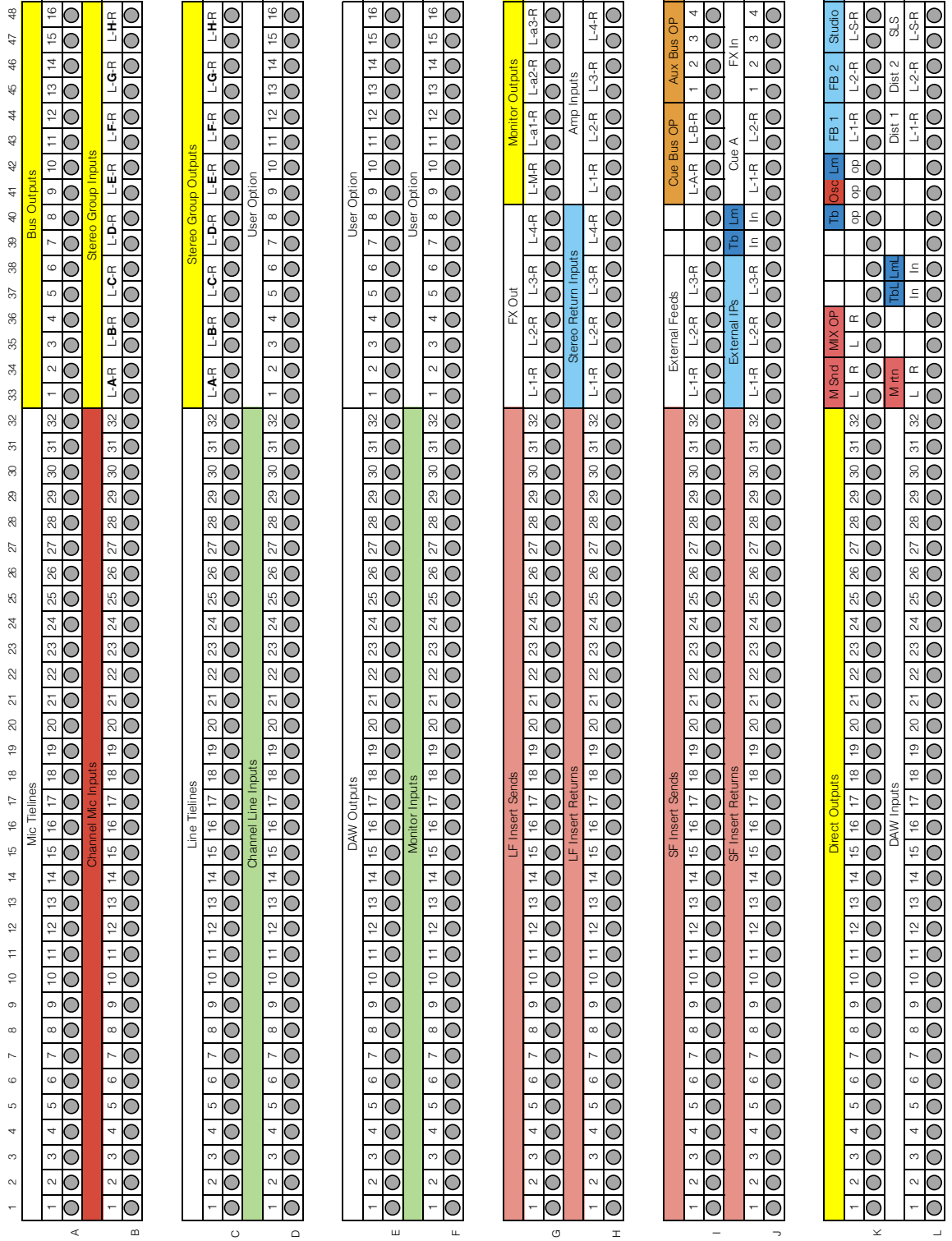

Appendix A - Performance Specification

Audio Performance

Default test conditions (unless otherwise stated):

- Source impedance of Test Set: 40 Ω
- Input impedance of Test Set: 200 k Ω
- Reference frequency: 1 kHz
- Reference level: 0 dBu where 0 dBu = 0.775 V into any load
- Unless specified, all unweighted measurements are specified as 20 Hz to 20 kHz band limited RMS and are expressed in units of dBu
- The onset of clipping (for headroom measurements) should be taken as 1% THD
- All distortion measurements are specified with a 36 dB/Octave low pass filter at 20 kHz and are expressed as a percentage
- All levels are intended balanced

Unless otherwise quoted all figures have a tolerance of ± 0.5 dB or 5%.

The performance figures quoted are with the console in the 'standard' configuration, i.e. Blank panels in the upper 6U 19" centre section, no additional electronics in the centre section and with the Stereo Group faders in the fader 'tray' and the Centre Section above, i.e. in the closest position to the operator.

PureDrive™ Channel Input Microphone/Line Amplifier

Measurement	Conditions	Value
Gain	**dependent on potentiometer tolerances	Mic Amp Gain Variable from +5 dB to +70 dB** Line Amp Gain Variable from -10 dB to +55 dB**
Input Impedance		1.4 k Ω
Max Input Level	1% THD	Mic Amp : +21 dBu
Output Headroom		>+26.5 dBu at onset of clipping
Frequency Response	- 20 Hz to 20 kHz - -3 dB high rolloff	- +0/-0.2 dB - > 90 kHz
THD+Noise	(-10 dBu applied, +30 dB gain) @ 1 kHz (-10 dBu applied, +30 dB gain) @ 10 kHz	- <0.004% at 1 kHz (20 Hz to 20 kHz) - <0.018% at 10 kHz (20 Hz to 40 kHz)
CMRR	(-10 dBu applied, +30 dB gain)	- > 57.5 dB 20 Hz to 20 kHz
Equivalent Input Noise (EIN)	Mic Amp, 150 Ω termination, maximum gain	- <-127.0 dBu (A-weighted)

Monitor Input Line Input Amplifier

Measurement	Conditions	Value
Gain	**dependent on potentiometer tolerances	Variable from -20 dB to +20 dB**
Input Impedance		10 k Ω
Max Input Level	1% THD	>+28 dBu before clipping
Output Headroom		>+27.5dBu at onset of clipping
Frequency Response	- 20 Hz to 20 kHz - -3 dB high rolloff	+0/-0.03 dB > 156 kHz
THD+Noise	(-10 dBu applied, +20 dB gain) @ 1 kHz (-10 dBu applied, +20 dB gain) @ 10 kHz	<0.0003% at 1 kHz (20 Hz to 20 kHz) <0.0009% at 10 kHz (20 Hz to 40 kHz)
CMRR		> 65 dB 20 Hz to 20 kHz
Equivalent Input Noise (EIN)	150 Ω termination, maximum gain	<-104 dBu

Channel Equaliser

Signal applied to line input and measured at the channel insert send. EQ switched in with EQ controls centred in shelf mode.

Measurement	Conditions	Value
Output Headroom		>+26.5 dBu at onset of clipping
THD+Noise	+20 dBu @ 1 kHz +20 dBu @ 10 kHz	<0.003% at 20 dBu @1 kHz (filter 20 Hz to 20 kHz) <0.003% at 20 dBu @10 kHz (filter 20 Hz to 40 kHz)
Noise		<-80dBu

Overall Channel Signal Chain Specifications

Signal applied to Line Input of a channel and routed to specified output by shortest path. All controls set flat, out or at unity gain as appropriate. Pan set to full left or right.

Measurement	Conditions	Value
	Auxiliary Send, Track Bus and Main Mix Bus Outputs	
Output Headroom	into 600 Ω at onset of clipping into 10 k Ω at onset of clipping	>24 dBu >26.5 dBu
THD+Noise	+20 dBu @ 1 kHz +20 dBu @ 10 kHz	<0.0008% @1 kHz (filter 20 Hz to 20 kHz) <0.0008% @10 kHz (filter 20 Hz to 40 kHz)
Frequency Response		
Track Buses	- 20 Hz to 20 kHz - -3 dB high rolloff	+0/-0.3 dB >70 kHz
Main Mix Bus	- 20 Hz to 20 kHz - -3 dB high rolloff	+0/-0.3 dB >70 kHz
Auxilliary Buses	- 20 Hz to 20 kHz - -3 dB high rolloff	+0/-0.3 dB >70 kHz
Pot centre detent accuracy:		+/-1 dB, typically <0.5 dB

Crosstalk

Signal applied to Line Input of a mono channel, and routed to specified output by shortest path. All controls set flat, out or at unity gain as appropriate. Pan set to full left or right.

Measurement	Conditions	Value
Channel Muting	20 Hz to 20 kHz	<-100 dB
Maximum Fader Attenuation	20 Hz to 20 kHz	<-89 dB
Pan pot Isolation	20 Hz to 20 kHz	<-55 dB
Routing Channel to Main Mix		<-94 dB from 20 Hz to 20 kHz
Routing Channel to Track Buses	Channel routed to all buses apart from one under test Channel not routed	<-64 dB from 20 Hz to 20 kHz <-113 dB from 20 Hz to 20 kHz
Mic Input	-50 dBu applied to Mic Input at maximum gain, measured at Direct Output, Monitor path selected	<-95 dB

Overall Console Noise

Measured at main Mix outputs, channels routed to Mix Bus as required with pans / balance controls centred, using Line input with termination. All controls set flat, out or at unity gain as appropriate, channel and master faders calibrated for 0dB.

Measurement	Conditions	Value
Line to Mix (Pan to centre)	1 channel routed 16 channels routed 24 channels routed** 32 channels routed**	<-93 dBu <-85 dBu <-83 dBu <-79 dBu

**Origin 32 only

Environmental Requirements

Temperature range:

Operating: +1 to 30 °C (+34 to 86 °F).

Storage: -20 to 50 °C (-4 to 122 °F).

Appendix B - ORIGIN Block Diagram

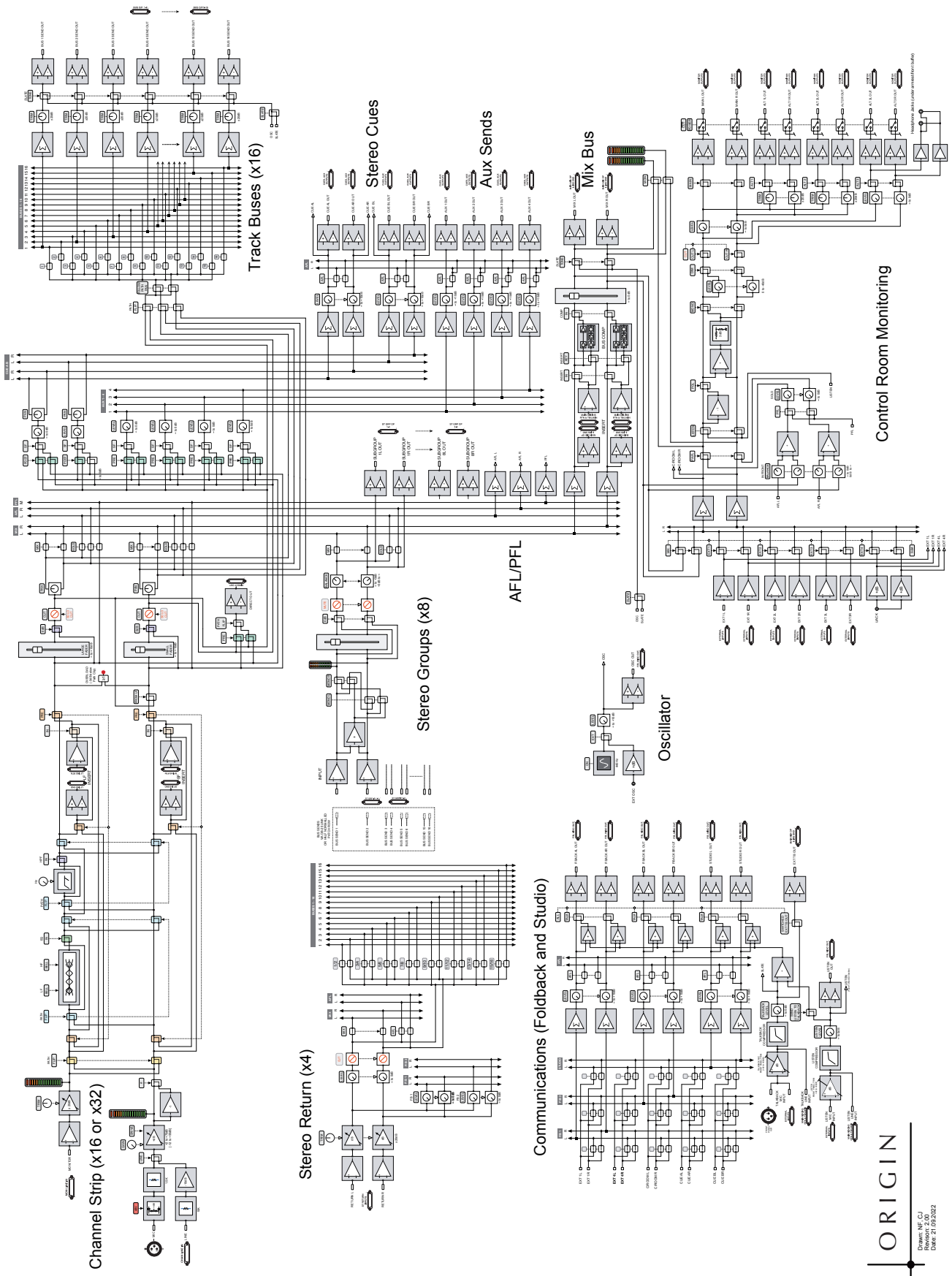

ORIGIN
 Drawn: NF_CJ
 Revision: 5.0.0
 Date: 21/10/2022

Appendix B - ORIGIN EVO Block Diagram

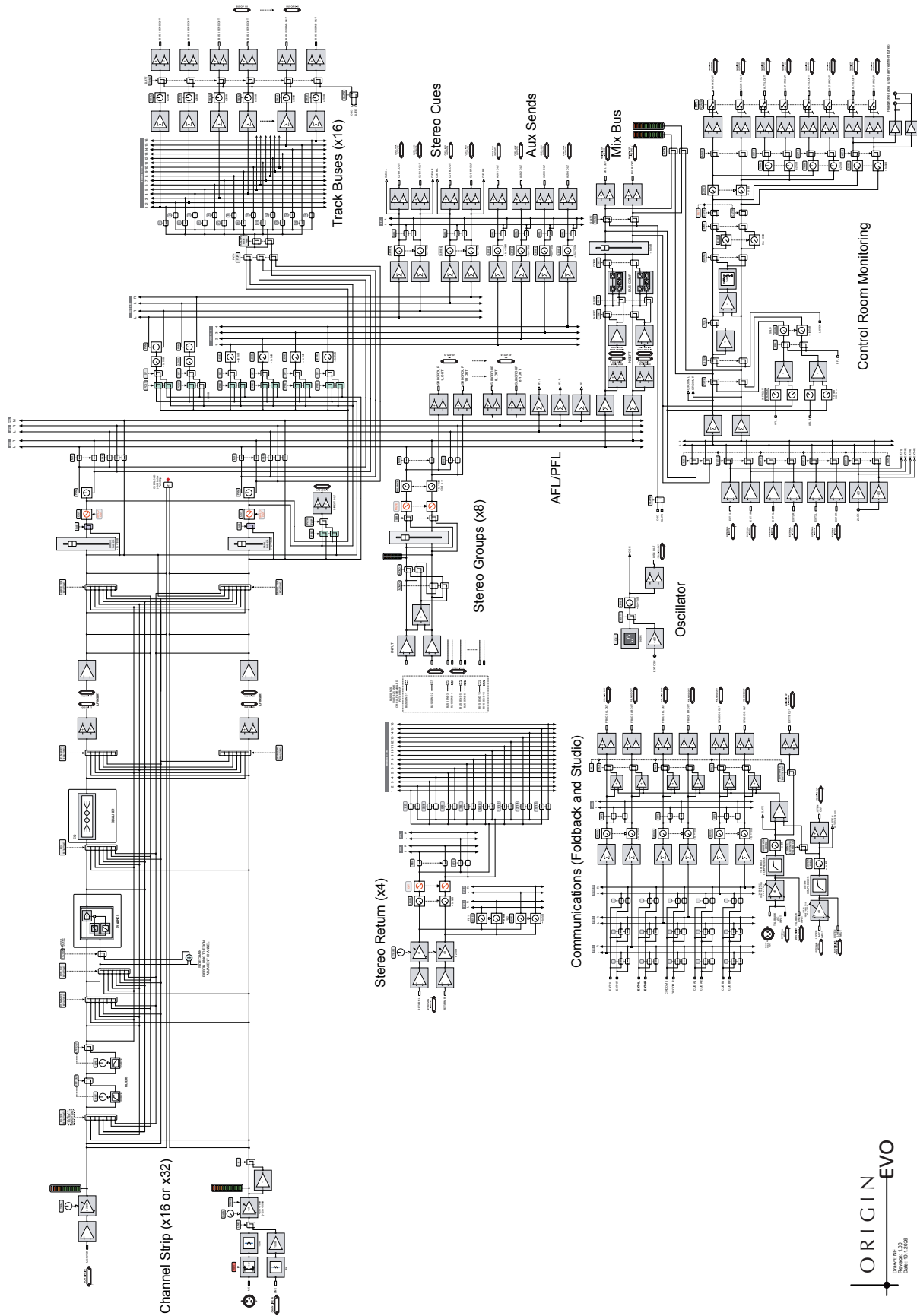

ORIGIN EVO
ORIGIN EVO
 ORIGIN EVO
 ORIGIN EVO

